

Technical Information

## Monoblock Valves

GDV25 / GDV45 / GSCV60 / GDV70 / GDV80 / GDV120 / GDV160





## RYAN HYDRAULICS

Keep the concept seeking excellence, RYAN try our best to create more value for you with products and service.

# RYAN Hydraulics

## About RYAN

RYAN's manufacture was established in 1986, focusing on providing customers with quality hydraulic components and solutions to hydraulic system in the applications of engineering machinery, mobile industries, agricultural machinery, aviation, mining, and other fields. Main products include gear pump, gear motor, flow divider, orbital motor, load sensing proportional valve, monoblock valve, sectional valve, manifold assembly and hydraulic power unit as well.

## Long-term development strategy

Reducing emissions by new energy is one of RYAN's long-term strategies. RYAN will be providing innovative technologies, products, and services for the global development of new energy, moving towards a century development strategy, and writing a century-new chapter in the hydraulic field.



### Innovation leads the future

Through a few decades of development, Ryan has built an intelligent manufacturing factory, gathering international R&D talents, accumulating rich R&D and manufacturing experience, possessing independent intellectual property rights, continuously providing customers with new products and technologies, and creating value for all of the customers.

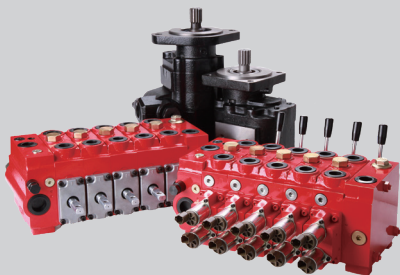

## Monoblock Valve Series

	<b>05-13</b>	L	GDV25 Series
GDV45 Series	<b>14-24</b>		
	<b>25-34</b>	L	GSCV60 Series
GDV70 Series	<b>35-45</b>		
	<b>46-58</b>	L	GDV80 Series
GDV120 Series	<b>59-67</b>		
	<b>68-76</b>	L	GDV160 Series
LS-TW-20F Series	<b>77</b>		
	<b>78</b>	L	LKF Series



## GDV25 Series Monoblock Valves

	05	└ Main Features
Technical Data ┘	05	
	06	└ Performance Data
Basic Operating Principle ┘	07	
	08-09	└ Dimensions
Inlet Port Options ┘	10	
	10	└ Return Port Options
Power Beyond Options ┘	10	
	11	└ Typical Spool Functions
Drive Options ┘	12	
	13	└ Ordering Code
Ordering Example ┘	13	

## GDV25 Series Monoblock Valves

### Main Features

- Cast iron body.
- Spring cap, mechanical detent cap are made by die cast aluminum.  
Parallel circuit. Inlet passage has a load check valve.
- Provides manual control and wire pulling control modules.
- Provides power beyond options.
- Provides mechanical detent.
- Provides different spool functions to satisfy the needs for customers to control double and single cylinders, as well as to control hydraulic motors.  
Provide excellent flow characteristics and small operating force.
- Provides 6 different assemblies from 1 spool to 6 spools.
- 

### Technical Data

Rated flow rate	25 L/min	With NBR seals	-20°C- 80°C
Maximum flow rate	30 L/min	With FKM seals	-20°C- 100°C
Maximum pressure at P port	250 bar	Spool stroke (1/2 position)	+5.5/-5.5mm
Maximum pressure at A/ B port	250 bar	With floating function (1/2 / F position)	+5.5/-5.5 -8mm
Maximum pressure at T port	25 bar	Recommend hydraulic oil viscosity range	15-75mm <sup>2</sup> /s
Internal leakage (@70 bar)	A/ B to T 30-35 cc/min	Recommend temperature range	-40°C- 60°C

## Performance Data

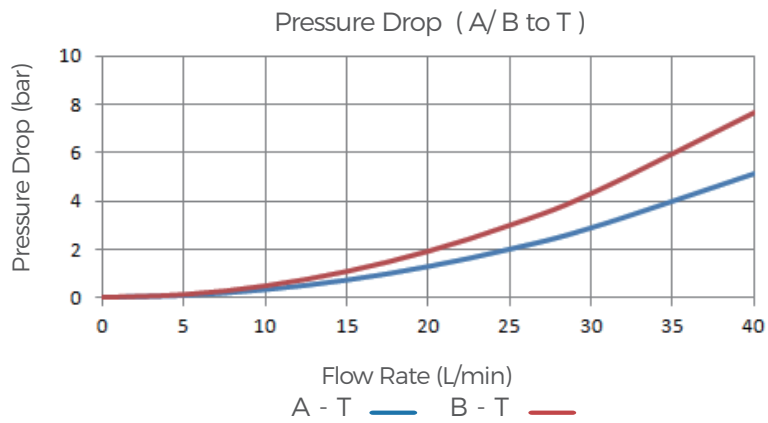
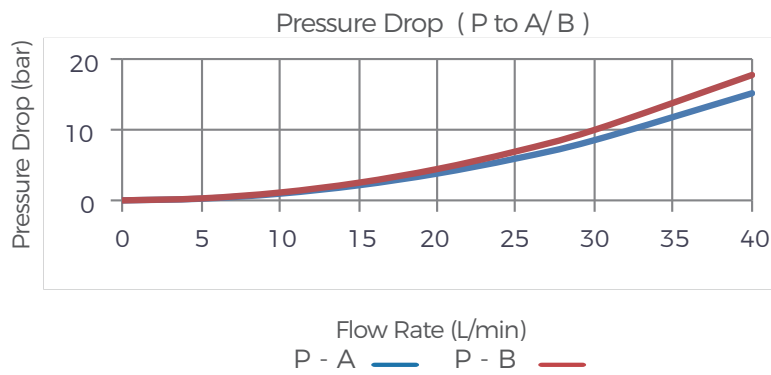
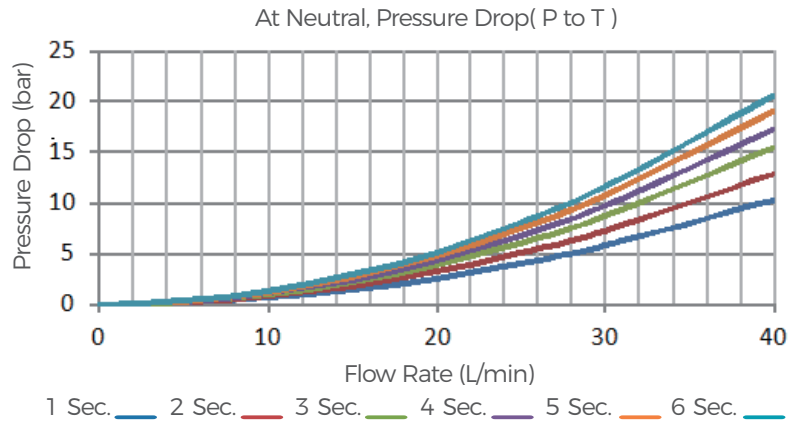



## Basic Operating Principle

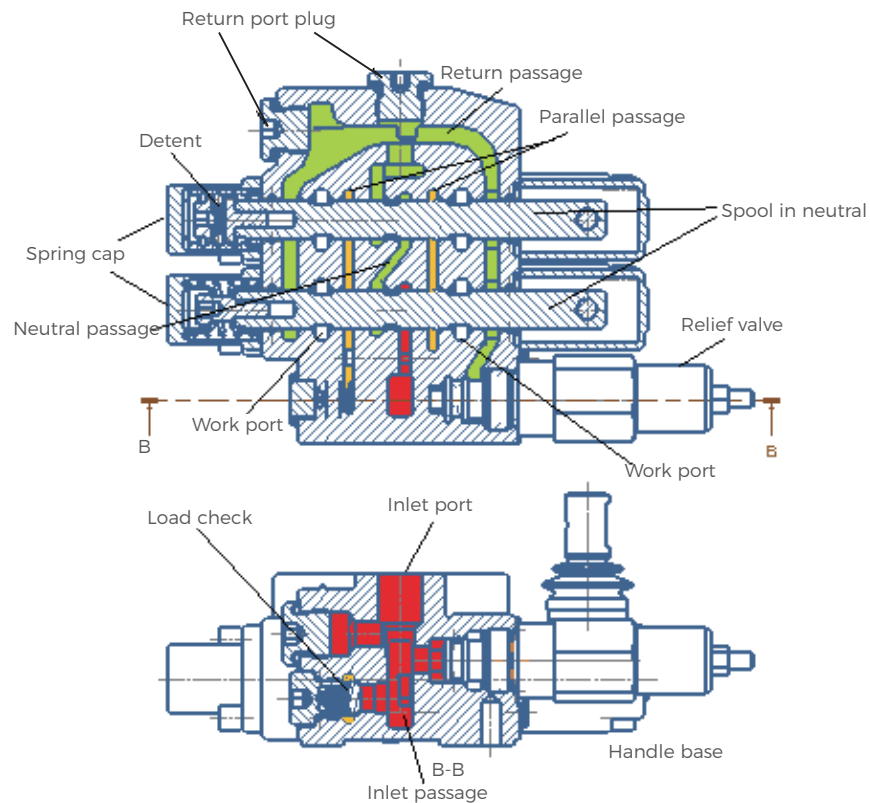

GDV25 series monoblock valve is an open center, 3-position 4-way valve. Flow from pump passes through inlet port and enters to inlet passage. The inlet passage connects two passages: one is through the load check into the parallel passage to supply flow to the working spool, another is to neutral passage. When spool is in neutral position, the parallel passage of spool is blocked. The oil from pump has to pass through neutral passage. When all spools are in neutral position, parallel passage for each spool is blocked, and neutral passage is wide open. Therefore, oil from pump is directly passing through the neutral passage to return passage to tank. It produces small pressure drop from P to T. When one of the spools is moved to 1 or 2 position, the spool blocked the neutral passage. The flow from pump has to pass load check valve and enter parallel passage, then through valve ports between parallel passage and spool to work port A or B.

For multi-spool monoblock valve, when one of its spools is in 1 or 2 position, the neutral passage of its downstream has no flow. The operator can operate more than one spool at a time, but the speed of the controlled device will be dependent on the load of the device.

## Dimensions

### GDV25-1: 1 Spool Monoblock Valve

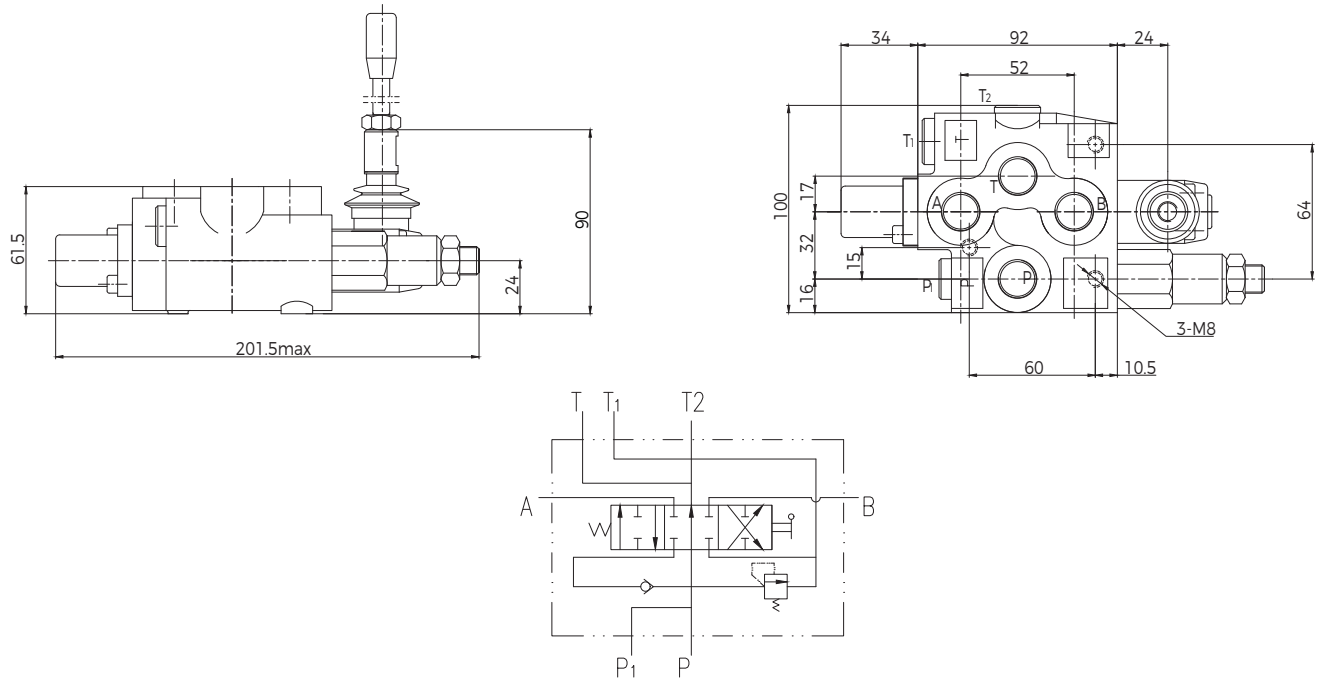

### GDV25-2: 2 Spools Monoblock Valve

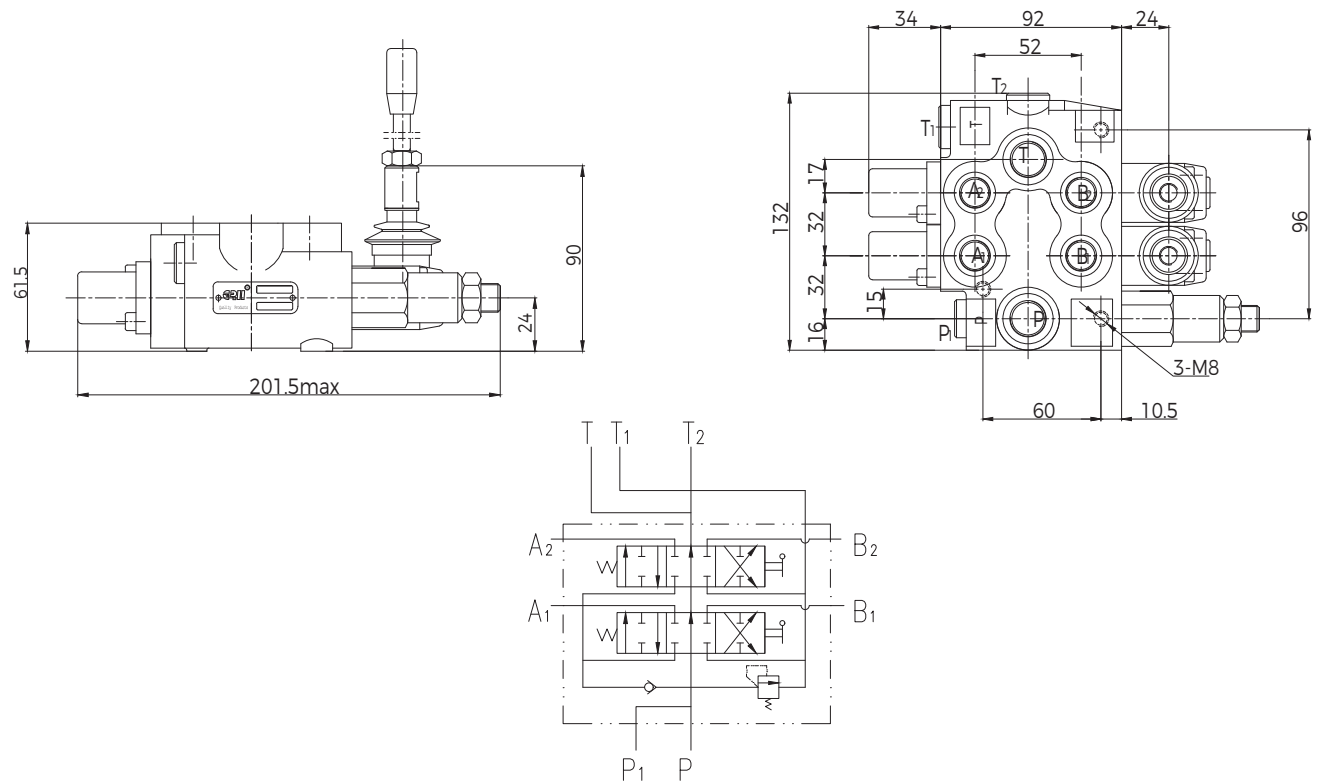

**GDV25-3: 3 Spools Monoblock Valve**

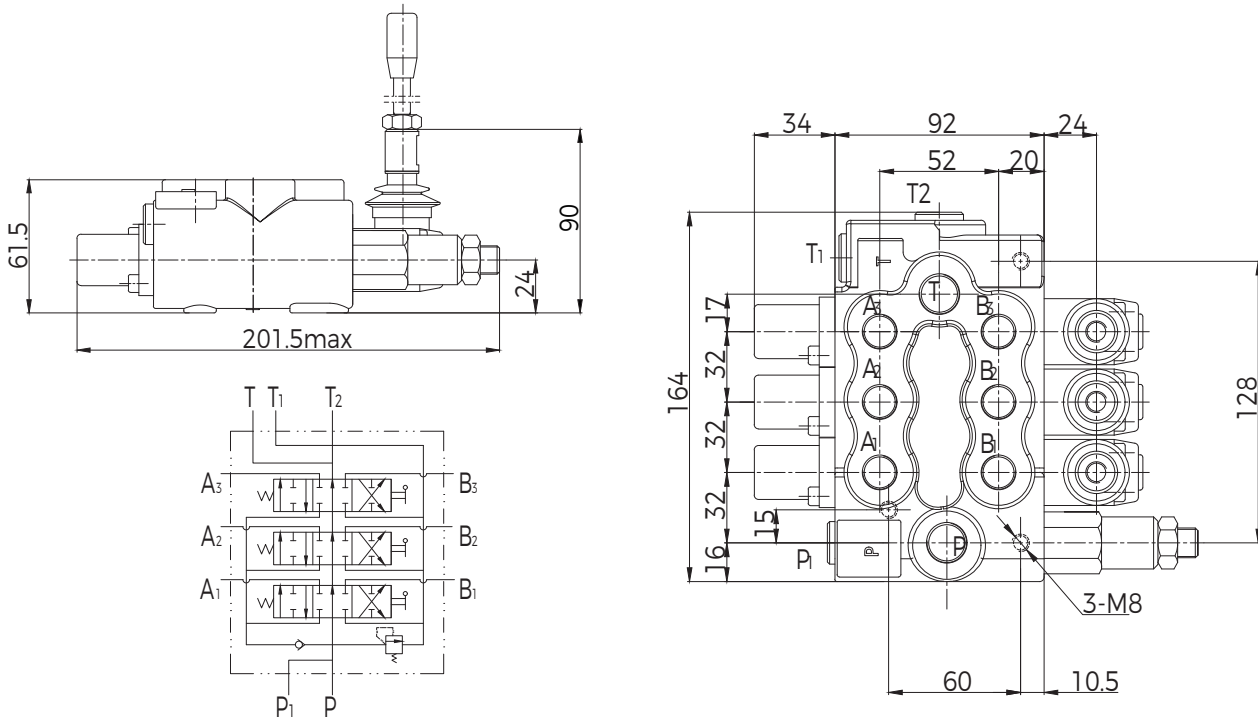

**GDV25-4: 4 Spools Monoblock Valve**

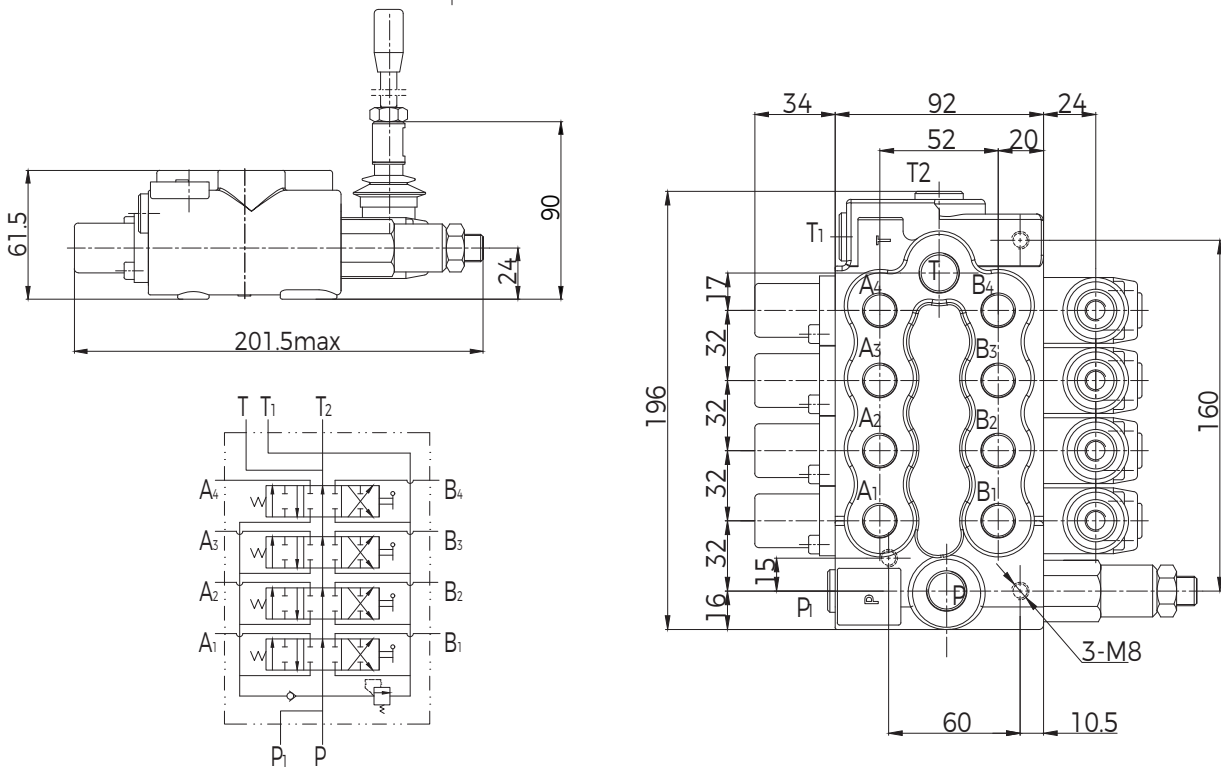

## Inlet Port Options

Option Code: P1 ( Port on the top)

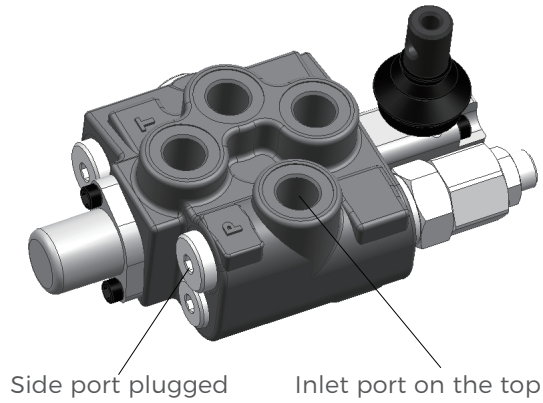

Option Code: P2 ( Port on the side)

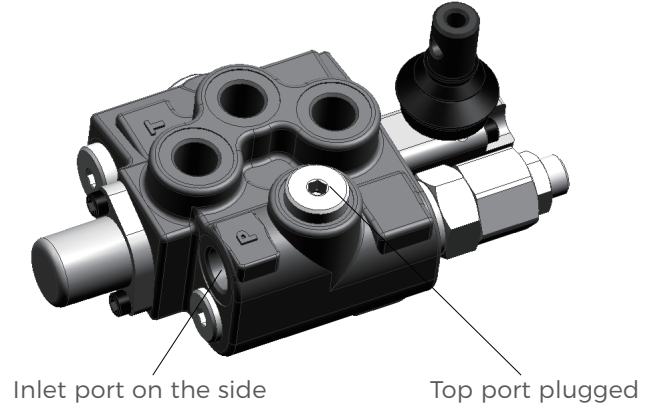

## Return Port Options

Port T Option Code: T1 ( T at the front)

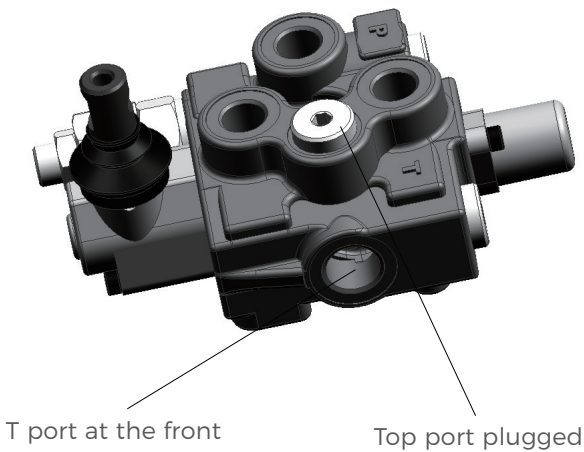

Port T Option Code: T2 ( T at the top)

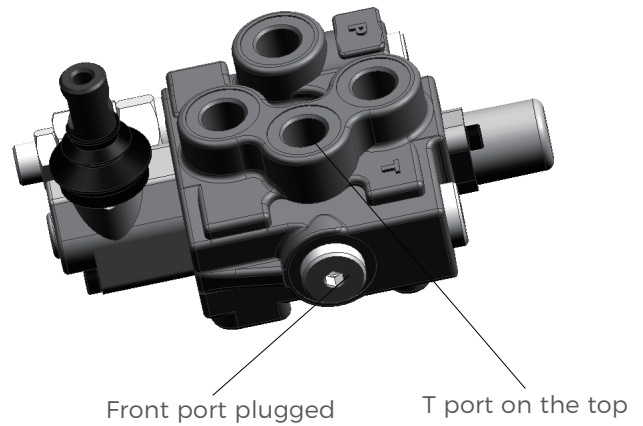

## Power Beyond Options



Power Beyond Option Code:

D1(Pump flow output to a power beyond connector)

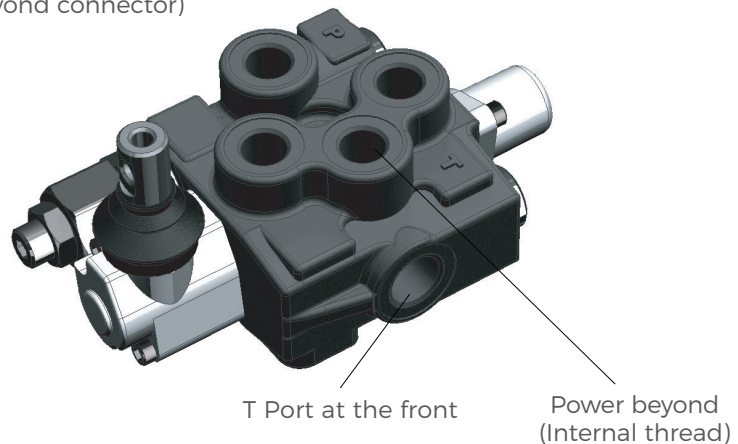

D0(Without power beyond)

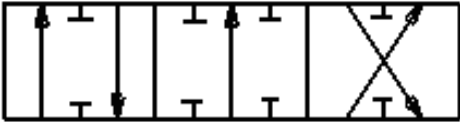
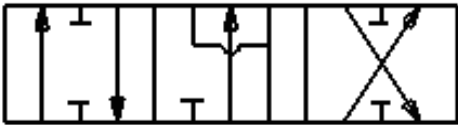
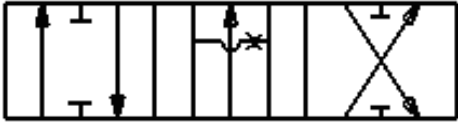
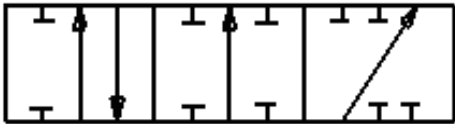
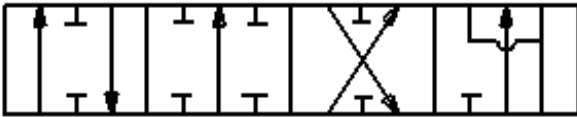

### Typical Spool Functions

Spool Code	Spool Type	Functions	Notes
FG1		3-position 4-way At neutral: P, T, A, B are all blocked	Double acting cylinder applications
FG2		3-position 4-way At neutral: P blocked, T, A, B connected	Hydraulic motor applications
FG3		3-position 4-way At neutral: P, A, B and T all connected	Hydraulic motor applications
FG4		3-position 3-way At neutral: P, T, A, B all blocked	Single acting cylinder applications
FG5		4-position 4-way At neutral: P, T, A and B are all blocked 4th position floating	Double acting cylinder applications
FG6		4-position 4-way At neutral: P blocked T, A and B are connected 4th position floating	Double acting cylinder or hydraulic motor applications

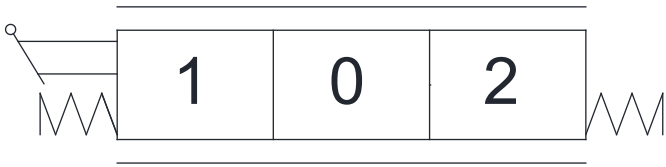
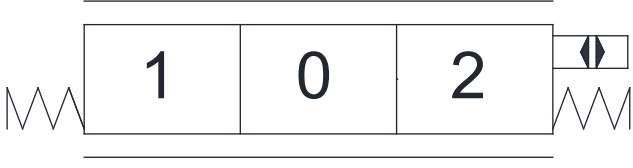
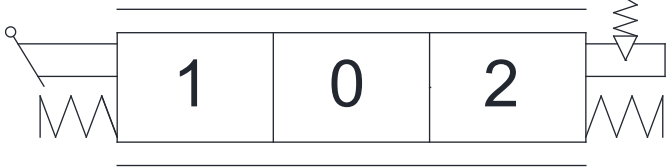
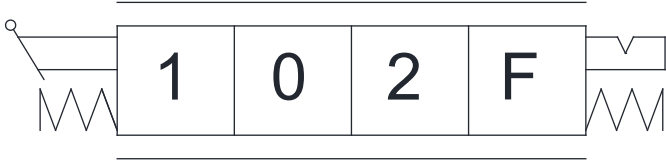
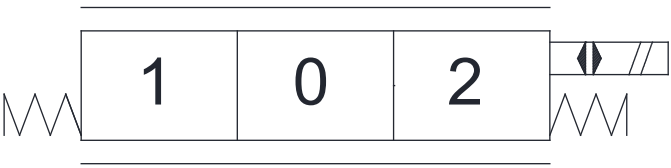
## Drive Options

Drive Style Code	Hydraulic Schematic	Functions
KQ1		Standard manual control
KQ2		Hydraulic remote
KQ3		Manual control with mechanical detent
KQ4 (not available)		Manual control with 4th position floating and detent
KQ5 (not available)		Electrical drive(on/off)
KQ6 (not available)		Electrical actuated with floating function

## Ordering Code

GDV25	-*	-P*	/***	-T*	-D*	-O1	-FG*	KQ*	-DC/**	-O2	.....
a	b	c	d	e	f	g	h	i	j	k	l

- |  |  |
|--|--|
| <ul style="list-style-type: none"> <li>Ⓐ Model</li> <li>Ⓑ Number of spools</li> <li>Ⓒ Inlet port code</li> <li>Ⓓ Inlet relief setting(bar)</li> <li>Ⓔ Return port code</li> <li>Ⓕ Power beyond</li> <li>Ⓖ First spool</li> </ul> | <ul style="list-style-type: none"> <li>Ⓗ Spool function<br/>FG1, FG2, FG3, FG4, FG5, FG6</li> <li>Ⓘ Drive code<br/>KQ1, KQ2, KQ3, KQ4, KQ5, KQ6</li> <li>⓵ Electrical option<br/>12VDC, 24VDC, 00=none electrical</li> <li>Ⓚ Second spool</li> <li>Ⓛ ..... </li> </ul> |
|--|--|

## Ordering Example

GDV25	-3	-P1	/210	-T1	-D1	-O1	-FG1	KQ1	-DC/00
a	b	c	d	e	f	g	h	i	j

- |  |  |
|--|--|
| <ul style="list-style-type: none"> <li>Ⓐ Model</li> <li>Ⓑ Three spools monoblock valve</li> <li>Ⓒ Inlet port on the top</li> <li>Ⓓ Inlet relief setting(210bar)</li> <li>Ⓔ Return port at the front</li> </ul> | <ul style="list-style-type: none"> <li>Ⓕ Power beyond</li> <li>Ⓖ First spool</li> <li>Ⓗ Spool function: O-type</li> <li>Ⓘ Drive mode: standard manual control</li> <li>⓵ Not electrical</li> </ul> |
|--|--|

-O2	-FG2	-KQ5	-DC/24	-O3	-FG2	-KQ2	-DC/00
k	l	m	n	o	p	q	r

- |   |   |
|---|---|
| <ul style="list-style-type: none"> <li>Ⓚ Second spool</li> <li>Ⓛ Spool function: Y-type</li> <li>Ⓜ Drive mode: electrical drive</li> <li>Ⓝ 24VDC</li> </ul> | <ul style="list-style-type: none"> <li>ⓐ Third spool</li> <li>Ⓟ Spool function: Y-type</li> <li>Ⓠ Drive mode: hydraulic remote</li> <li>Ⓡ Not electrical</li> </ul> |
|---|---|

## GDV45 Series Monoblock Valves

	<b>15</b>	<b>L</b> Main Features
Technical Data <b>L</b>	<b>15</b>	
	<b>16</b>	<b>L</b> Performance Data
Basic Operating Principle <b>L</b>	<b>17-18</b>	
	<b>19-20</b>	<b>L</b> Dimensions
Inlet Port Options <b>L</b>	<b>21</b>	
	<b>21</b>	<b>L</b> Return Port Options
Power Beyond Options <b>L</b>	<b>21</b>	
	<b>22</b>	<b>L</b> Typical Spool Functions
Drive Options <b>L</b>	<b>23</b>	
	<b>24</b>	<b>L</b> Ordering Code
Ordering Example <b>L</b>	<b>24</b>	



## GDV45 Series Monoblock Valves

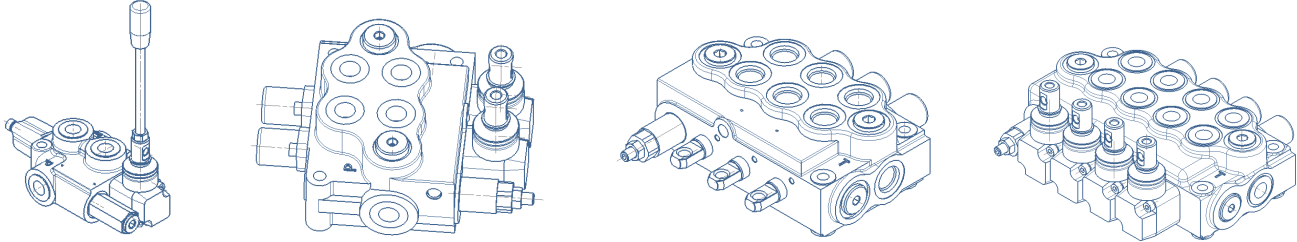

### Main Features

- Cast iron monoblock body.
- Spring cap and mechanical detent cap are made in die cast aluminum.
- Parallel circuit. Inlet passage has a load check valve.
- Provides manual control and wire pulling control modules.
- Provides power beyond options.
- Provides mechanical detent.
- Provides different spool functions to satisfy the needs for customers to control double and single cylinders, as well as to control hydraulic motors.
- Provide excellent flow characteristics and small operating force.
- Provides 6 different assemblies from 1 spool to 6 spools.

### Technical Data

Rated flow rate	45 L/min	With NBR seals	-20°C- 80°C
Maximum flow rate	55 L/min	With FKM seals	-20°C- 100°C
Maximum pressure at P port	310 bar	Spool stroke(1/2 position)	+7/-7 mm
Maximum pressure at A/B port	310 bar	With floating function (1/2 /F position)	+7/-7 -9 mm
Maximum pressure at T port	25 bar	Recommend hydraulic oil viscosity range	15-75 mm <sup>2</sup> /s
Internal leakage(@70 bar)	A/B to T 30-35cc/min	Recommend temperature range	-40°C- 60°C

## Performance Data

At Neutral, Pressure Drop ( P to T )

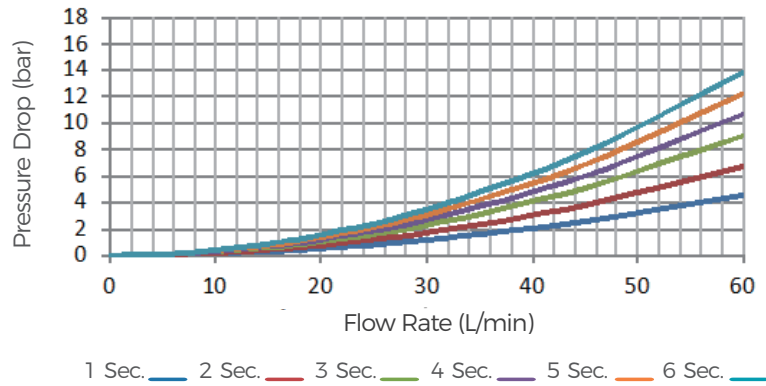

Pressure Drop(P to A/B)

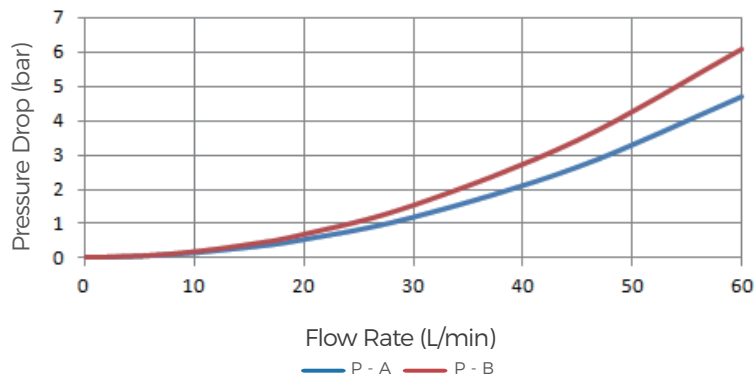

Pressure Drop(A/B to T)

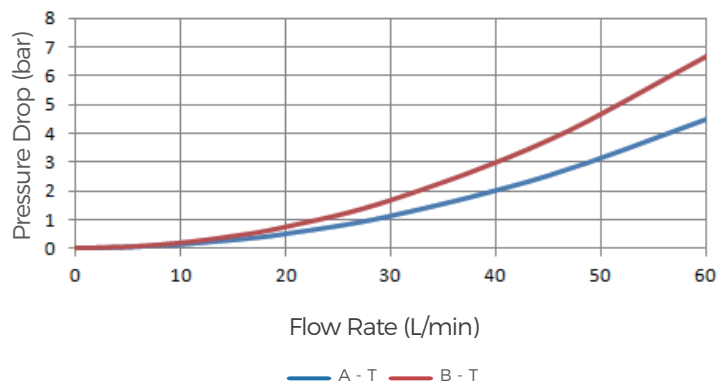

## Basic Operating Principle

### GDV45-1: 1 Spool Monoblock Valve

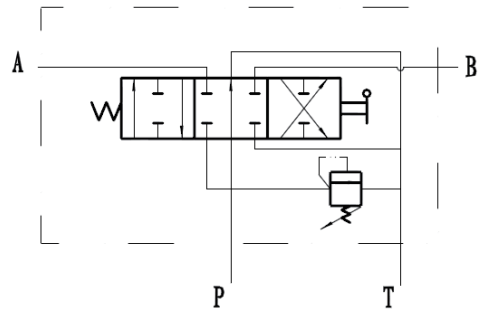
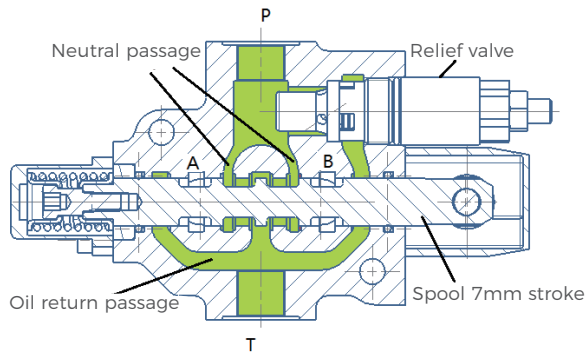

GDV45-1 is an one spool valve. It is also an open center 3-position 4-way valve. When spool is in neutral, flow from pump passes through neutral passage to tank, and produces very little pressure drop. When spool is moved to 1 or 2 position, the neutral passage is blocked by spool. The flow from pump has to pass through the parallel passage to provide flow to spools metering to work port. The spool stroke is 7 mm. For GDV45-1 monoblock valve, it cannot provide power beyond function.

### GDV45-2: 2 Spools Monoblock Valve

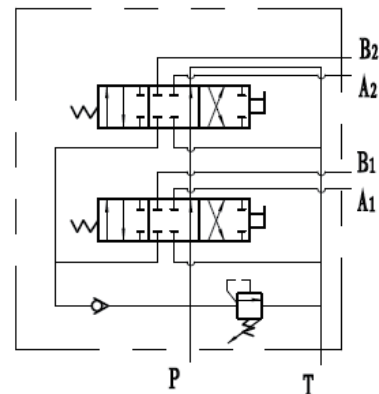
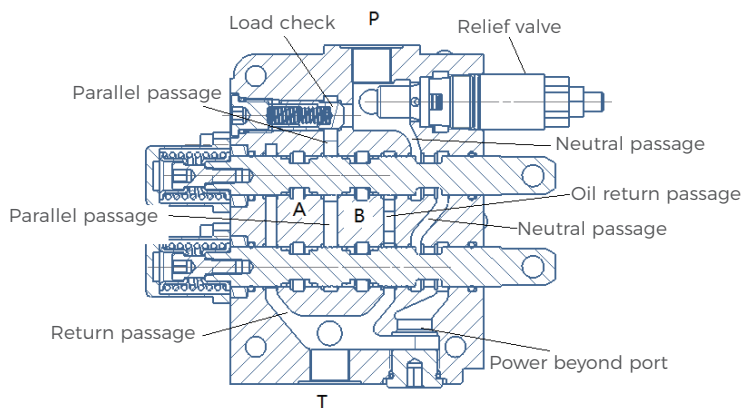

GDV45-2, two spools monoblock valve is also an open center 3-position 4-way valve. When spools are all in neutral, flow from pump passes through neutral passage to tank, and produces very little pressure drop. When one of the spools is moved to 1 or 2 position, the neutral passage is blocked by the spool. The flow from pump has to pass through the parallel passage to provide flow to spools metering to work port. There are options to choose for location of the inlet port and return port. There is also an option to have power beyond port. If first spool is moved to 1 or 2 position, then, the second spools neutral passage has no flow. The operator can operate two spools at the same time, but the speed of the controlled device is dependent on the load of the device.

## Basic Operating Principle

### GDV45-3: 3 Spools Monoblock Valve

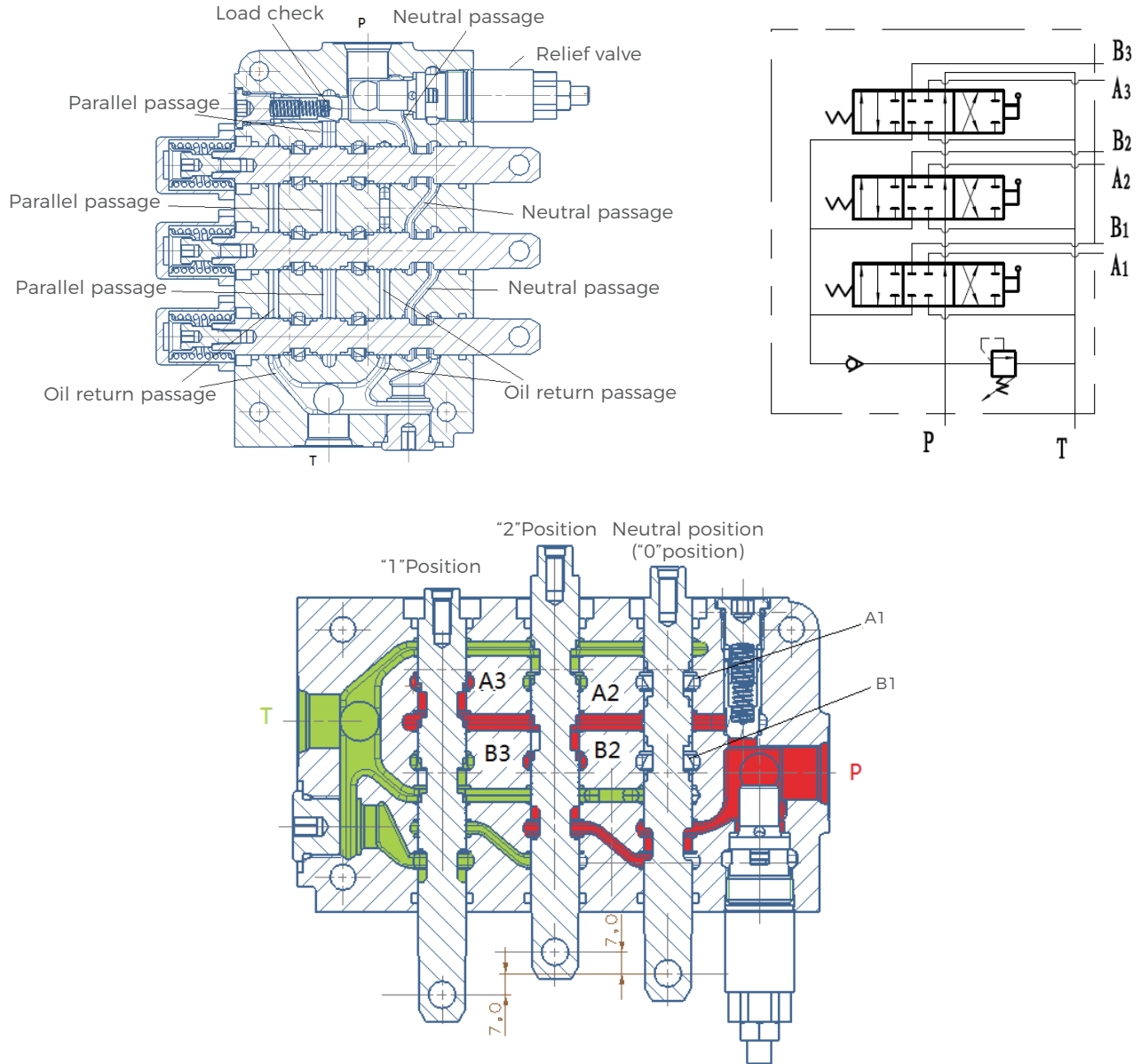

GDV45-3 is a three spools monoblock valve. It is also an open center 3-position 4-way valve. The three spools were moved as shown in the above picture. The first spool is in neutral (O position). The spool metering to A1 and B1 are all blocked. The second spool is moved to 2 position, flow from parallel passage flows through spool opening to B2 port, flow from A2 port returns through another opening spools. The third spool is moved to 1 position, flow from parallel passage flows to A3 through opening spool. Flow in B3 port flows to return passage through the another opening spools.



## Dimensions

### GDV45-3: 3 Spools Monoblock Valve

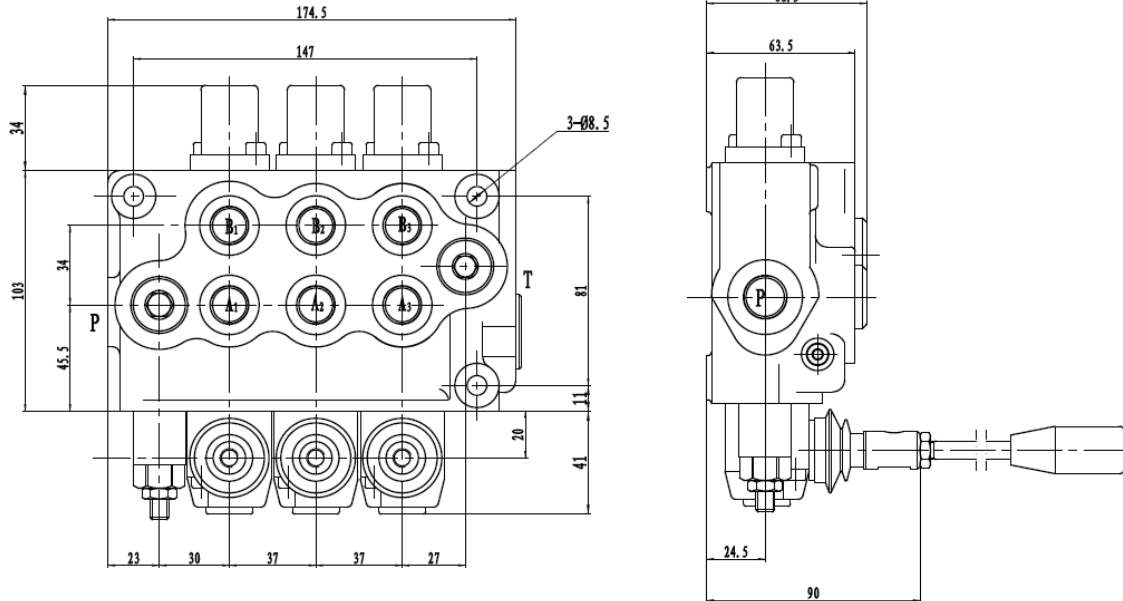

### GDV45-4: 4 Spools Monoblock Valve

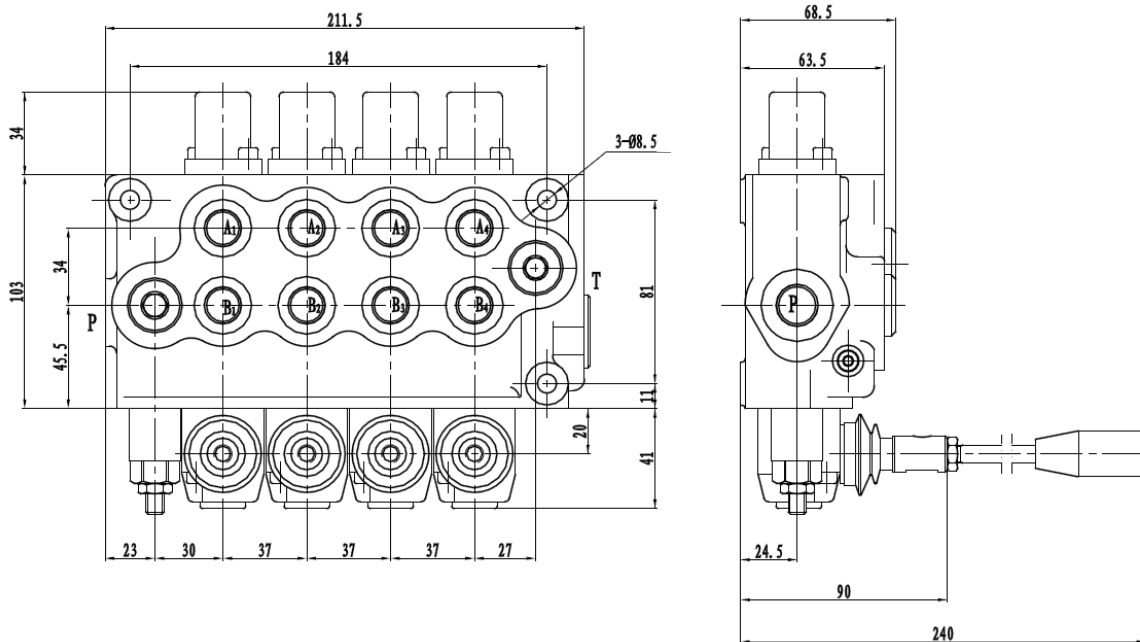

## Inlet Port Options

Inlet Option Code: P1 (Inlet port at the front)

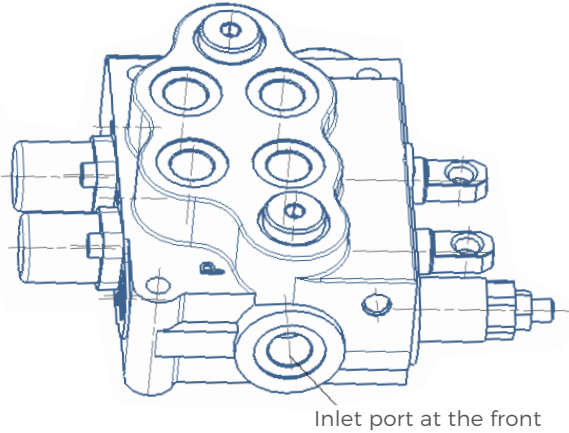

Inlet Port Option Code: P2 (Inlet port at the top)

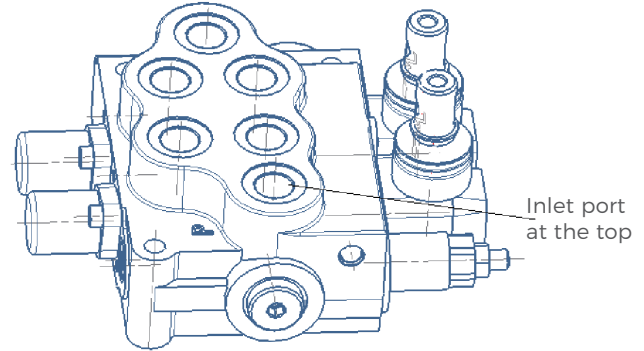

## Return Port Options

Return Port Option Code: T1 (Return port at the front)

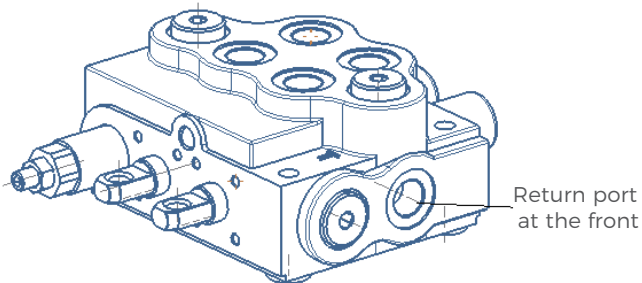

Return Port Option Code: T2 (Return port at the top)

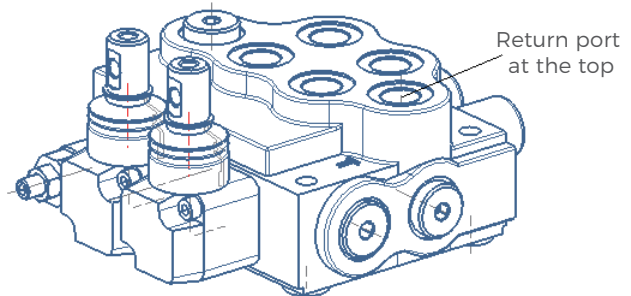

## Power Beyond Options



Power Beyond Option Code:

D1 (Pump flow output to a power beyond connector)

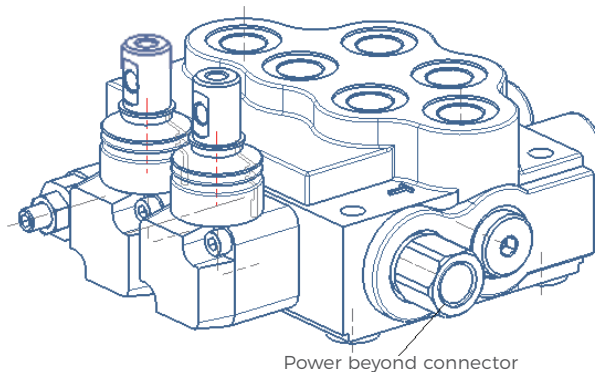
D0 (Without power beyond)

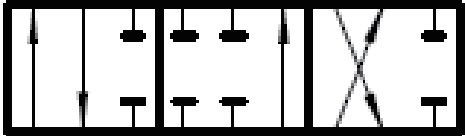
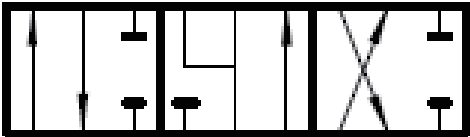
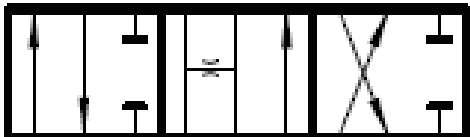
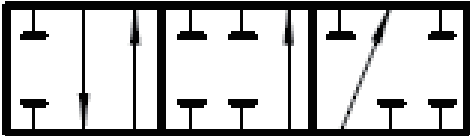

## Typical Spool Functions

Spool Code	Spool Type	Functions	Notes
FG1		3-position 4-way At neutral: P, T, A, B are all blocked	Double acting cylinder applications
FG2		3-position 4-way At neutral: P blocked, T, A, B connected	Hydraulic motor applications
FG3		3-position 4-way At neutral: P, A, B and T all connected	Hydraulic motor applications
FG4		3-position 3-way At neutral: P, T, A, B all blocked	Single acting cylinder applications
FG5 (not available)		4-position 4-way At neutral: P, T, A, and B are all blocked 4th position floating	Double acting cylinder applications
FG6 (not available)		4-position 4-way At neutral: P blocked T, A and B are connected 4th position floating	Double acting cylinder or hydraulic motor applications



## Drive Options

Drive Style Code	Hydraulic Schematic	Functions
KQ1		Standard manual control
KQ2		Hydraulic remote
KQ3		Manual control with mechanical detent
KQ4 (not available)		Manual control with 4th position floating and detent
KQ5 (not available)		Electrical drive(on/off)
KQ6 (not available)		Electrical actuated with floating function

## Ordering Code

<b>GDV45</b>	<b>-*</b>	<b>-P*</b>	<b>/***</b>	<b>-T*</b>	<b>-D*</b>	<b>-O1</b>	<b>-FG*</b>	<b>KQ*</b>	<b>-DC/**</b>	<b>-O2</b>	<b>.....</b>
a	b	c	d	e	f	g	h	i	j	k	l

- |  |   |
|--|---|
| <ul style="list-style-type: none"> <li>Ⓐ Model</li> <li>Ⓑ Number of spools</li> <li>Ⓒ Inlet port code</li> <li>Ⓓ Inlet relief setting(bar)</li> <li>Ⓔ Return port code</li> <li>Ⓕ Power beyond</li> <li>Ⓖ First spool</li> </ul> | <ul style="list-style-type: none"> <li>ⓑ Spool function<br/>FG1, FG2, FG3, FG4, FG5, FG6</li> <li>Ⓙ Drive code<br/>KQ1, KQ2, KQ3, KQ4, KQ5, KQ6</li> <li>ⓓ Electrical option<br/>12VDC, 24VDC, 00=none electrical</li> <li>Ⓚ Second spool</li> <li>Ⓛ .....</li> </ul> |
|--|---|

## Ordering Example

<b>GDV45</b>	<b>-3</b>	<b>-P1</b>	<b>/210</b>	<b>-T1</b>	<b>-D1</b>	<b>-O1</b>	<b>-FG1</b>	<b>KQ1</b>	<b>-DC/00</b>
a	b	c	d	e	f	g	h	i	j

- |  |  |
|--|--|
| <ul style="list-style-type: none"> <li>Ⓐ Model</li> <li>Ⓑ Three spools monoblock valve</li> <li>Ⓒ Inlet port at the front</li> <li>Ⓓ Inlet relief setting(210bar)</li> <li>Ⓔ Return port at the front</li> </ul> | <ul style="list-style-type: none"> <li>Ⓕ Power beyond</li> <li>Ⓖ First spool</li> <li>ⓑ Spool function: O-type</li> <li>Ⓙ Standard manual control</li> <li>ⓓ Not electrical</li> </ul> |
|--|--|

<b>-O2</b>	<b>-FG2</b>	<b>-KQ5</b>	<b>-DC/24</b>
k	l	m	n

<b>-O3</b>	<b>-FG2</b>	<b>-KQ2</b>	<b>-DC/00</b>
o	p	q	r

- |   |   |
|---|---|
| <ul style="list-style-type: none"> <li>Ⓚ Second spool</li> <li>Ⓛ Spool function: Y-type</li> <li>Ⓜ Drive code: electrical drive</li> <li>Ⓝ 24VDC</li> </ul> | <ul style="list-style-type: none"> <li>ⓐ Third spool</li> <li>Ⓟ Spool function: Y-type</li> <li>Ⓞ Drive code: hydraulic remote</li> <li>Ⓡ Not electrical</li> </ul> |
|---|---|

## GSCV60 Seires Monoblock Valves

	26	└ Main Features
Technical Data ┘	26	
	27	└ Performance Data
Basic Operating Principle ┘	28	
	29	└ Dimensions
Inlet Port Options ┘	30	
	30	└ Oil Return Port Options
Typical Spool Functions ┘	31	
	32	└ Drive Options
Ordering Code ┘	33	
	34	└ Ordering Example

## GSCV60 Seires Monoblock Valve

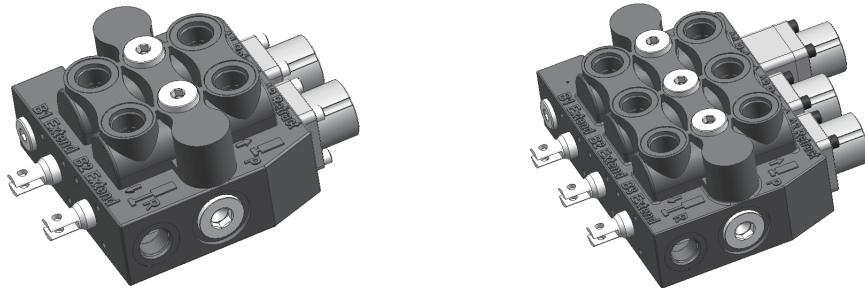

### Main Features

- Cast iron monoblock body.
- End cover with spring, end cover with mechanical position, made of cast aluminum.
- Parallel circuit, with load check valve at the inlet.
- Provide manual and wire control.
- Provide power beyond.
- Provide mechanical positioning.
- Provide various spool functions, double acting oil cylinders, single acting oil cylinders and hydraulic motors application.
- The valve has low operating force and good flow characteristics.
- This monoblock valve can be combined with an integrated valve with 2 to 3 valve spools.

### Technical Data

Rated flow rate	60 L/min	With NBR seals	-20°C-80°C
Maximum flow rate	80 L/min	With FKM seals	-20°C-100°C
Maximum pressure at P port	315 bar	Spool stroke	+7/-7 mm
Maximum pressure at A/B port	315 bar	Spool stroke with float	-14 mm
Maximum pressure at T port	25 bar	Recommended hydraulic oil viscosity	15-75mm <sup>2</sup> /s
Internal leakage (70bar): A/B to T oil port	35 cc/min	Recommended ambient temperature	-20°C-60°C

### Performance Data

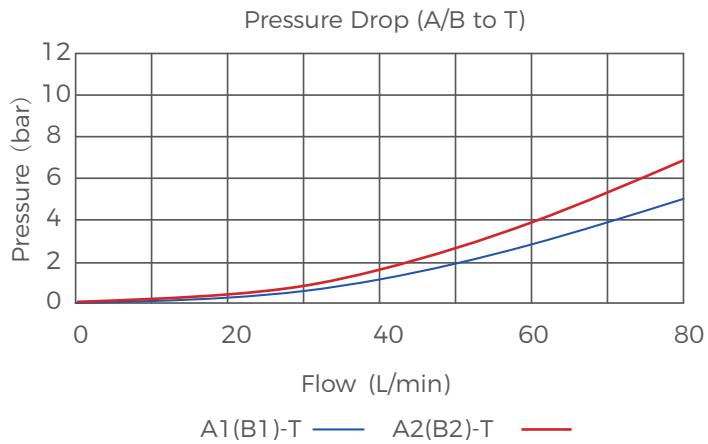
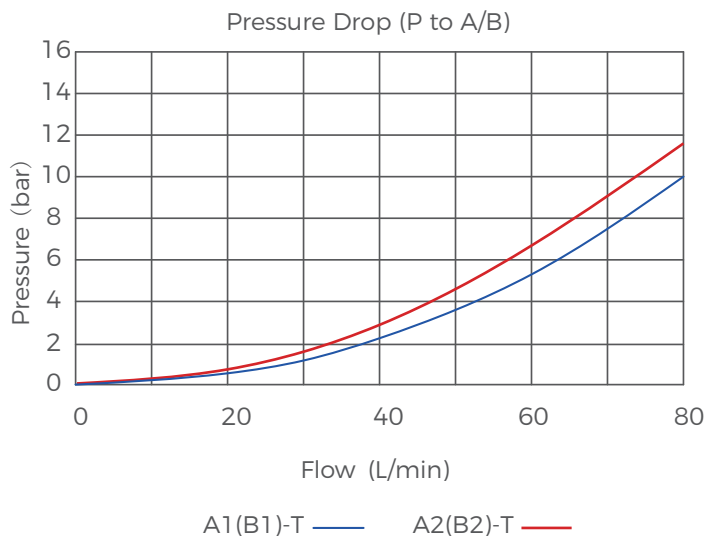
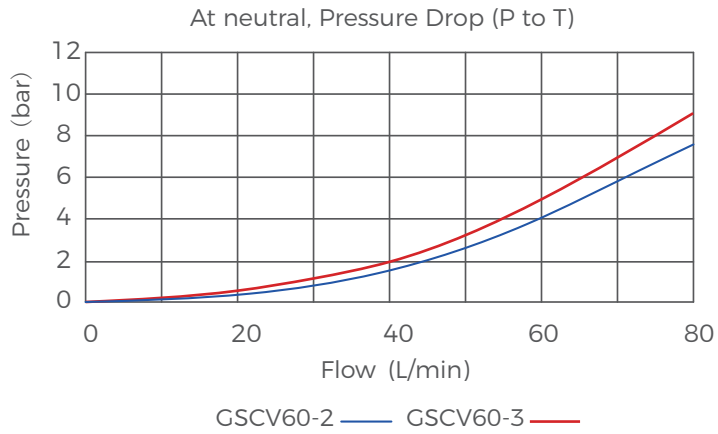

## Basic Operating Principle

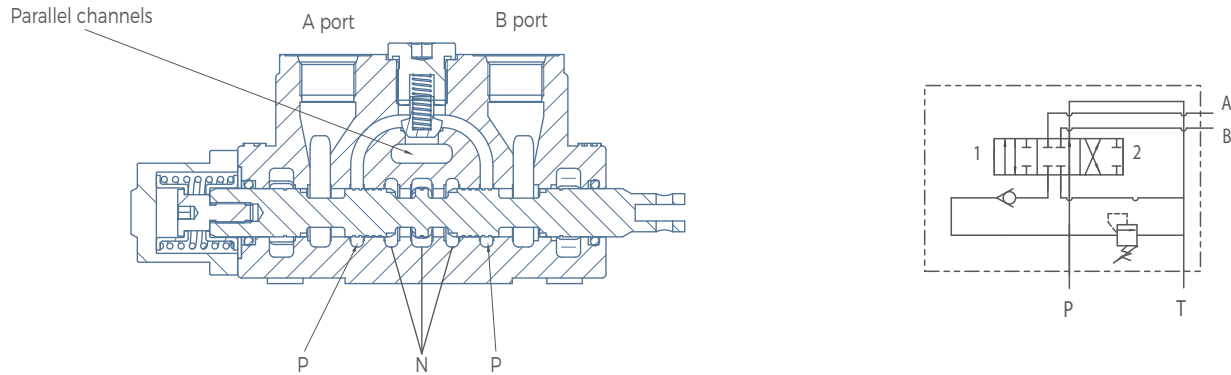

Generally speaking, the two spools and three spools valves of GSCV60 are open type 3-position 4-way valves. When the valve spool is in the middle position, the oil provided by the oil pump flows directly into the oil tank through the middle channel between the valve spool and the valve body, resulting in minimal pressure loss. When one of the valve spool moves to "1" or "2", the N-N neutral channel between the valve spool and the valve body is gradually blocked, and all flow from the oil pump enters the load check valve through a parallel oil circuit. After being throttled by the valve port, it enters the "A" or "B" port controlled by the valve spool.

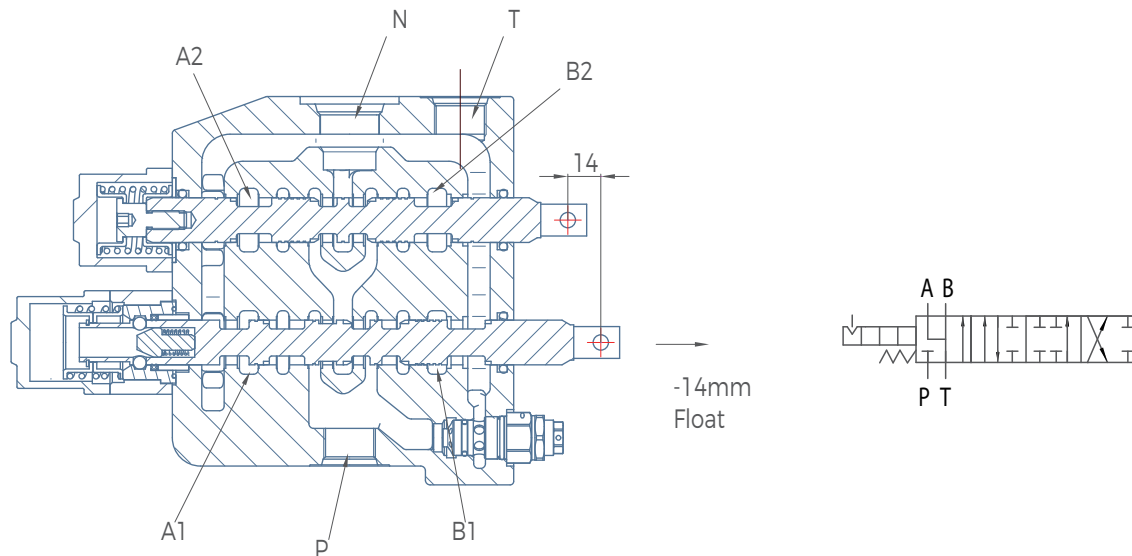

The first valve spool in the above figure is in the floating position, and the middle channel P-N can normally supply oil to the second valve spool, while the two working oil ports A1 and B1 are directly connected to the T port. When the second spool is moved to the reversing position, oil is supplied from the parallel channel to A2 or B2. The operator can simultaneously control the spools of two sections, and the speed of their control components depends on the size of the load.

## Dimensions

### GSCV60-2: 2 Spools Monoblock Valve

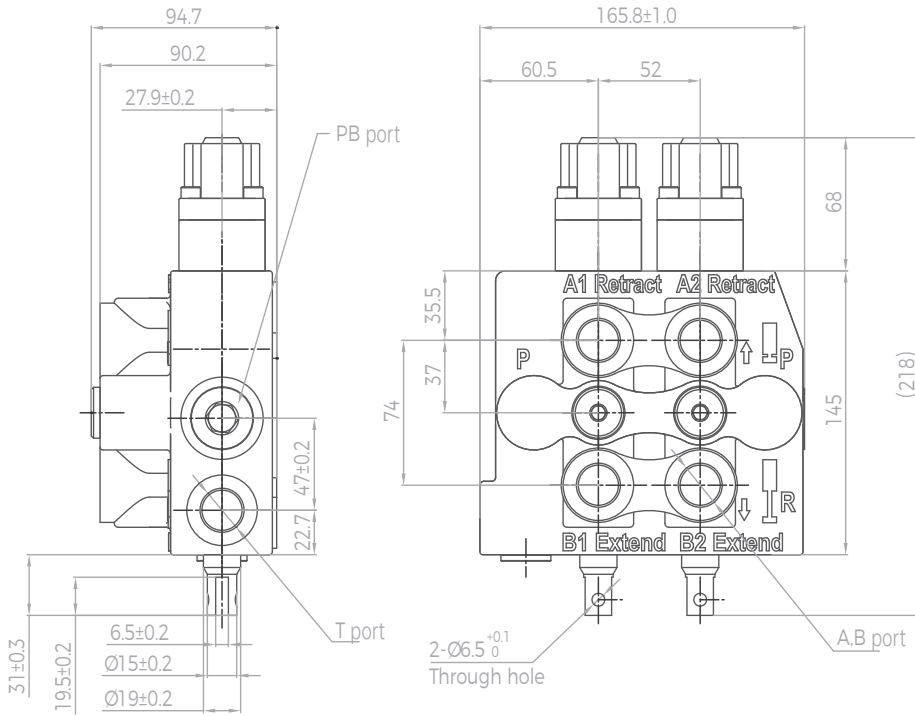

### GSCV60-3: 3 Spools Monoblock Valve

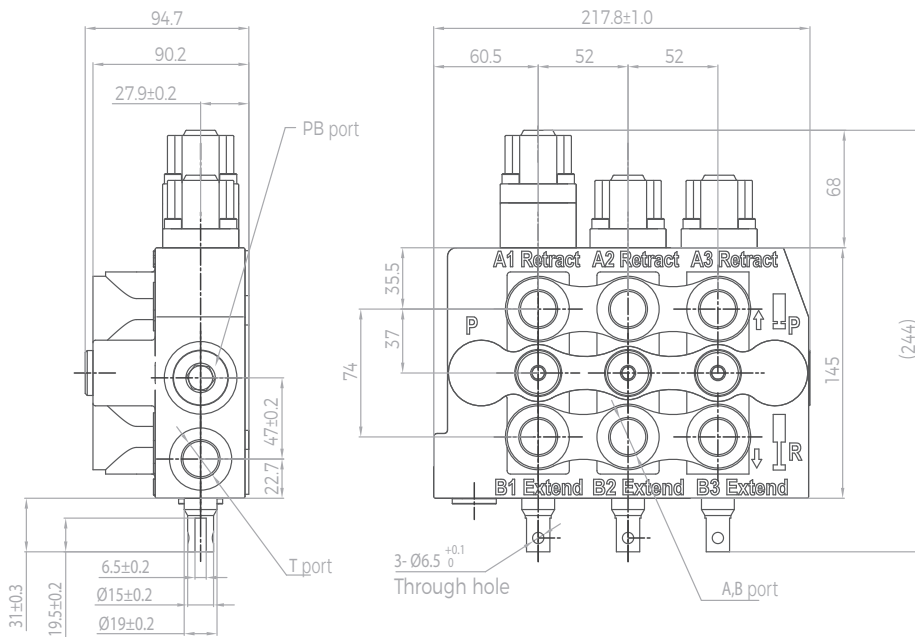

## Inlet Port Options

Inlet port selection code: P1 ( Inlet port on the front side)

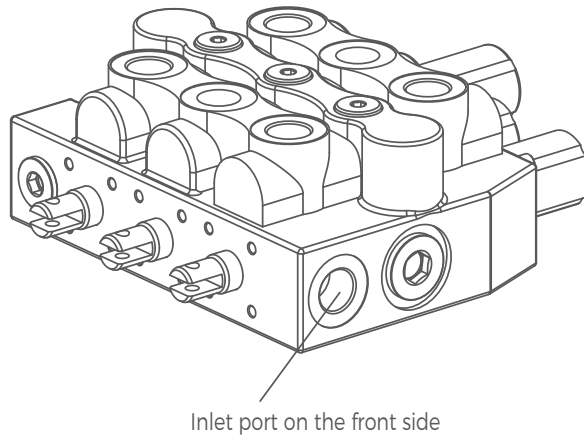

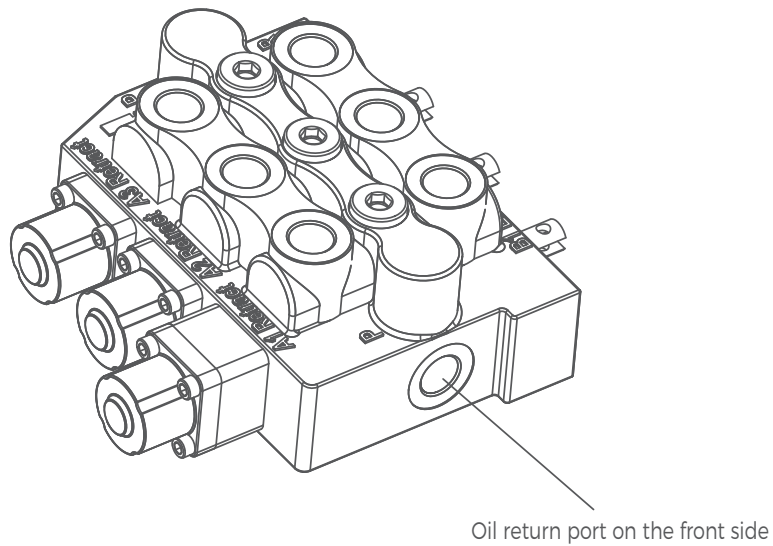

## Oil Return Port Options

Oil return port selection code: T1 ( Oil return port on the front side)



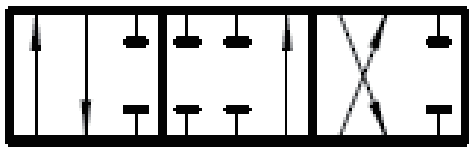
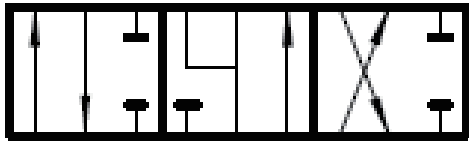
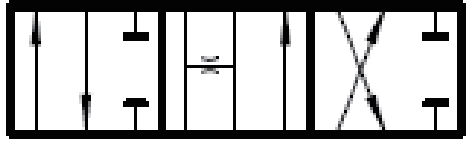
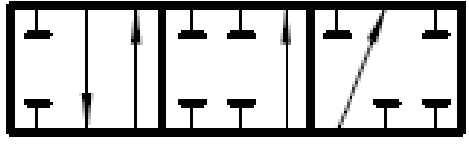

## Typical Spool Functions

Spool Code	Spool Type	Functions	Notes
FG1		3-position 4-way At neutral: P, T, A, B are all blocked	Double acting cylinder applications
FG2		3-position 4-way At neutral: P blocked, T, A, B connected	Hydraulic motor applications
FG3		3-position 4-way At neutral: P, A, B and T all connected	Hydraulic motor applications
FG4		3-position 3-way At neutral: P, T, A, B all blocked	Single acting cylinder applications
FG5 (not available)		4-position 4-way At neutral: P, T, A and B are all blocked 4th position floating	Double acting cylinder applications
FG6 (not available)		4-position 4-way At neutral: P blocked, T, A and B are connected 4th position floating	Double acting cylinder or hydraulic motor applications

## Drive Options

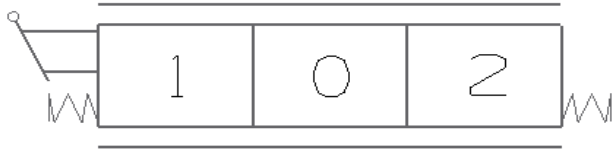
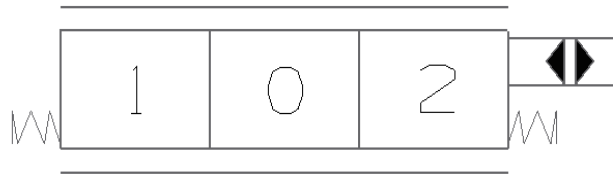
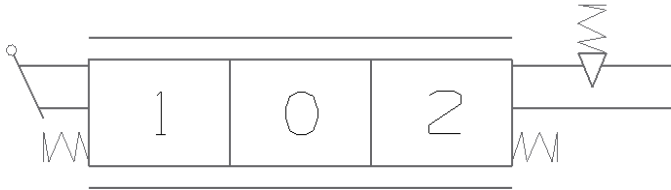
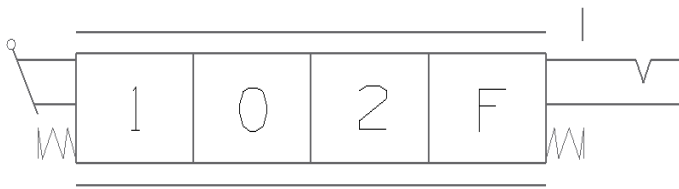
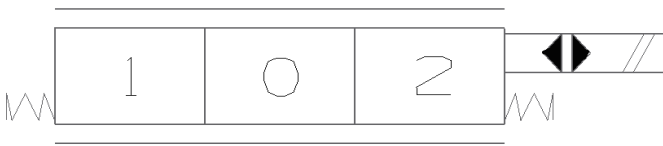
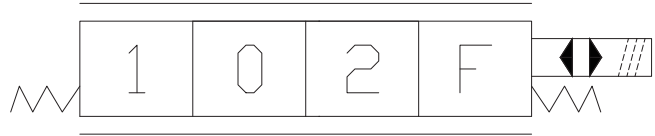
Drive Style Code	Hydraulic Schematic	Functions
KQ1		Standard manual control
KQ2		Hydraulic remote
KQ3		Manual control with mechanical detent
KQ4		Manual control with 4th position floating and detent
KQ5 (not available)		Electrical drive(on/off)
KQ6 (not available)		Electrical actuated with floating function

## Ordering Code

GSCV60	-*	-P*	/***	-T*	-D*	-O1	-FC*	KQ*	-DC/**	-AR/***
a	b	c	d	e	f	g	h	i	j	k

- Ⓐ Model
- Ⓑ Spools
- Ⓒ Inlet port code
- Ⓓ Inlet relief setting (bar)
- Ⓔ Return port code
- Ⓕ Power beyond
- Ⓖ First spool
- Ⓗ Spool function  
FG1, FG2, FG3, FG4, FG5, FG6
- Ⓘ Drive code  
KQ1, KQ2, KQ3, KQ4, KQ5, KQ6
- Ⓙ 12 or 24VDC, 00=none electrical
- Ⓚ Port A overload setting pressure 250bar,  
if there is no need, set the pressure 000

-BR/***	-O2	.....
l	m	n

- Ⓛ Port B overload setting pressure 250bar
- Ⓜ Second spool
- Ⓝ .....

## Ordering Example

GSCV60	-3	-P1	/210	-T1	-D1	-O1	-FG1	KQ1	-DC/00	-AR/250	-BR/190
a	b	c	d	e	f	g	h	i	j	k	l

- |   |   |
|---|---|
| <ul style="list-style-type: none"> <li>Ⓐ Model</li> <li>Ⓑ 3 Spools</li> <li>Ⓒ Inlet port on the front side</li> <li>Ⓓ Inlet relief setting (210bar)</li> <li>Ⓔ Oil return port on the front side</li> <li>Ⓕ Power beyond</li> </ul> | <ul style="list-style-type: none"> <li>Ⓖ First spool</li> <li>Ⓗ Spool function: O-type</li> <li>Ⓘ Drive code: standard manual control</li> <li>⓵ No electrical</li> <li>Ⓚ Port A overload setting pressure 250bar</li> <li>Ⓛ Port B overload setting pressure 190bar</li> </ul> |
|---|---|

-O2	-FG2	-KQ5	-DC/24	-AR/000	-BR/000	-O3	-FG2	-KQ2	-DC/00	-AR/220	-BR/000
m	n	o	p	q	r	s	t	u	v	w	x

- |   |  |
|---|--|
| <ul style="list-style-type: none"> <li>Ⓜ Second spool</li> <li>Ⓝ Spool function: Y-type</li> <li>Ⓞ Drive code: electric drive</li> <li>Ⓟ 24VDC</li> <li>Ⓠ Port A without overload valve</li> <li>Ⓡ Port B without overload valve</li> </ul> | <ul style="list-style-type: none"> <li>Ⓢ Third spool</li> <li>Ⓣ Spool function: Y-type</li> <li>Ⓤ Drive code: hydraulic remote</li> <li>Ⓥ No electrical</li> <li>Ⓦ Port A overload setting pressure 220bar</li> <li>Ⓧ Port B without overload valve</li> </ul> |
|---|--|

## GDV70 Series Monoblock Valves

	36	└ Main Features
Technical Data ┘	36	
	37	└ Performance Data
Basic Operating Principle ┘	38	
	39-40	└ Dimensions
Inlet Port Options ┘	41	
	41	└ Return Port Options
Power Beyond Options ┘	41	
	42	└ Typical Spool Functions
Drive Options ┘	43	
	44	└ Ordering Code
Ordering Example ┘	45	

## GDV70 Series Monoblock Valves

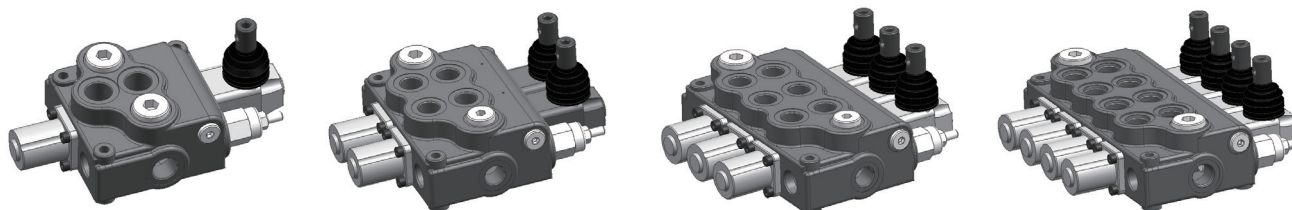

### Main Features

- Cast iron monoblock body.
- Spring cap and mechanical detent cap are made in die cast aluminum.
- Parallel circuit. Inlet passage has a load check valve.
- Provides manual control and wire pulling control modules.
- Provides power beyond options.
- Provides mechanical detent.
- Provides different spool functions to satisfy the needs for customers to control double and single cylinders, as well as to control hydraulic motors.
- Provide excellent flow characteristics and small operating force.
- Provides 6 different assemblies from 1 spool to 6 spools.

### Technical Data

Rated flow rate	70 L/min	With NBR seals	-20°C-80°C
Maximum flow rate	80 L/min	With FKM seals	-20°C-100°C
Maximum pressure at P port	310 bar	Spool stroke (1, 2 position)	+7/-7 mm
Maximum pressure at A/B port	310 bar	With floating function (1, 2, F position)	+7/-7 -9 mm
Maximum pressure at T port	25 bar	Recommend hydraulic oil viscosity range	15-75mm <sup>2</sup> /s
Internal leakage (@70bar)	A/ B to T 30-35 cc/min	Recommended temperature range	-40°C-60°C

## Performance Data

At Neutral, Pressure Drop ( P to T )

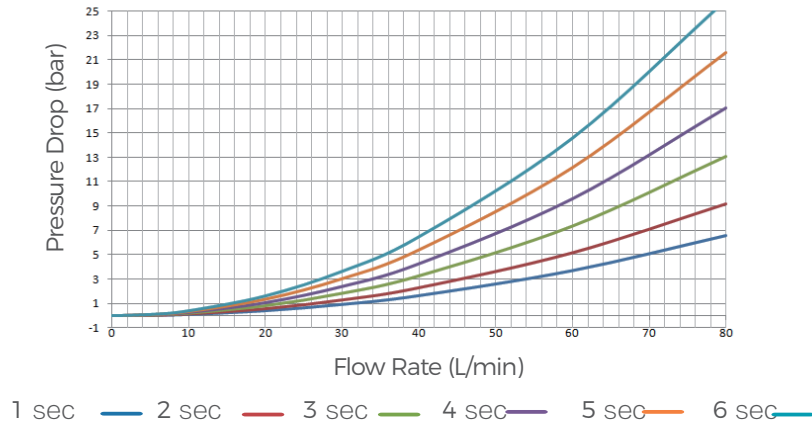

Pressure Drop ( P to A/B )

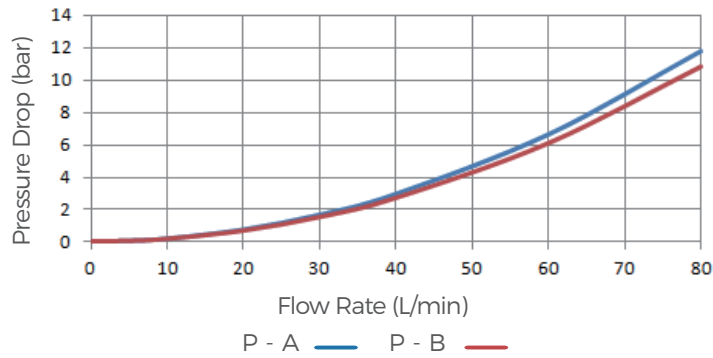

Pressure Drop ( A/B to T )

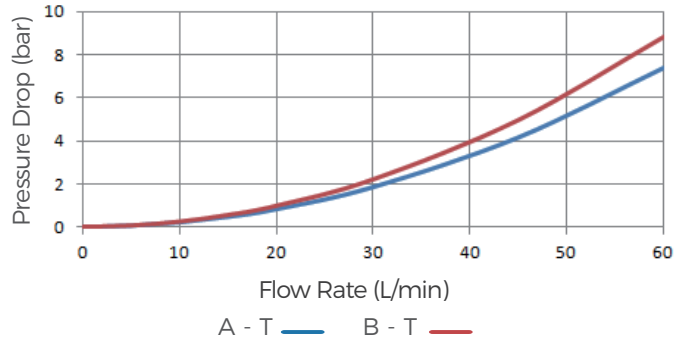

## Basic Operating Principle

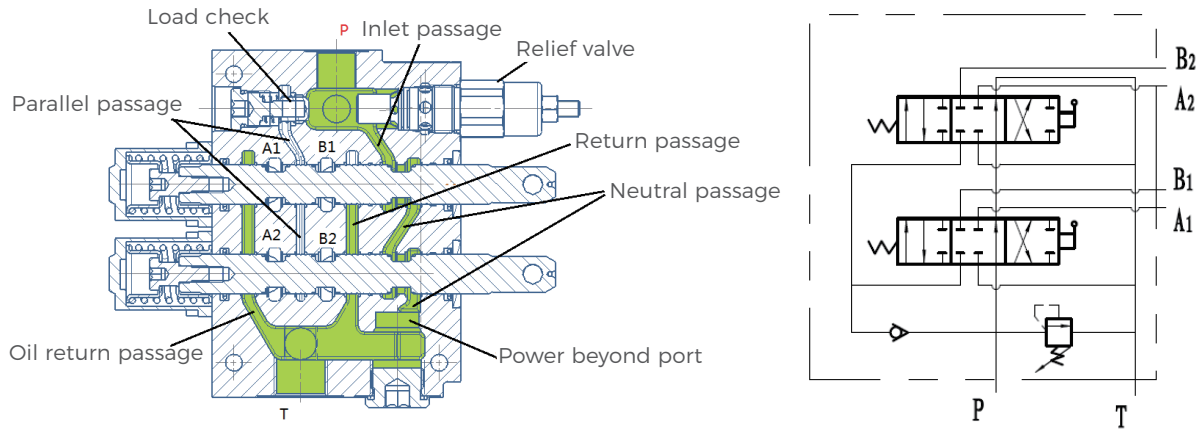

GDV-70 series monoblock valve is an open centered 3-position 4-way valve. When spool is in its neutral position, the flow from pump passes through the neutral passage to tank, with very low pressure drop. When one of the spool is moved to 1 or 2 position, the neutral passage is blocked. The flow from pump can only pass through load check to parallel passage, then through the spool opening to work port A or B.

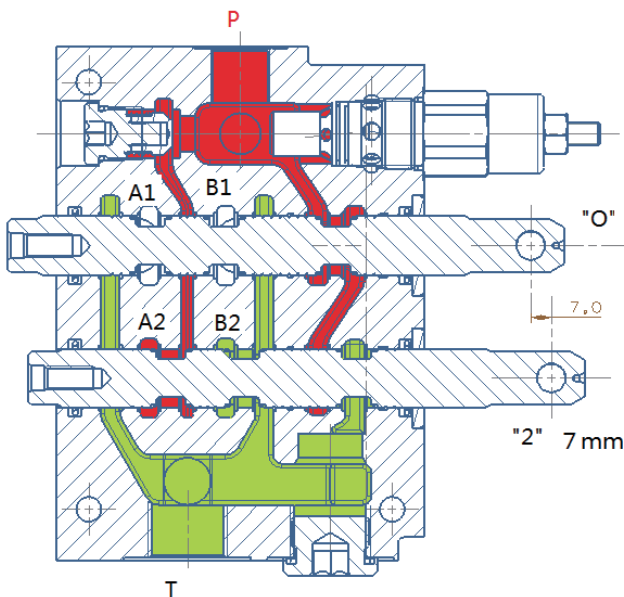

As shown in the picture, when first spool is in neutral, flow from pump passes through load check valve and enters the parallel passage to supply flow to both spools. Due to second spool is moved to 2 position, the flow from parallel passage flows to A2 through the spool opening. The flow from B2 flows to return passage through the spool's other opening. Neutral passage is blocked by the second spool.



## Dimensions

### GDV70-1: 1 Spool Monoblock Valve

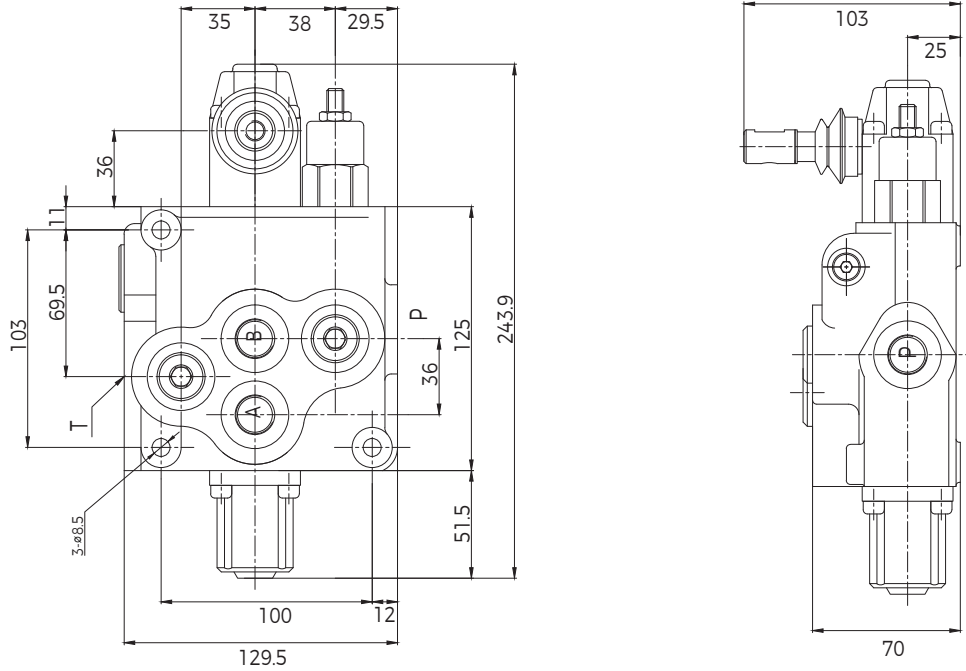

### GDV70-2: 2 Spools Monoblock Valve

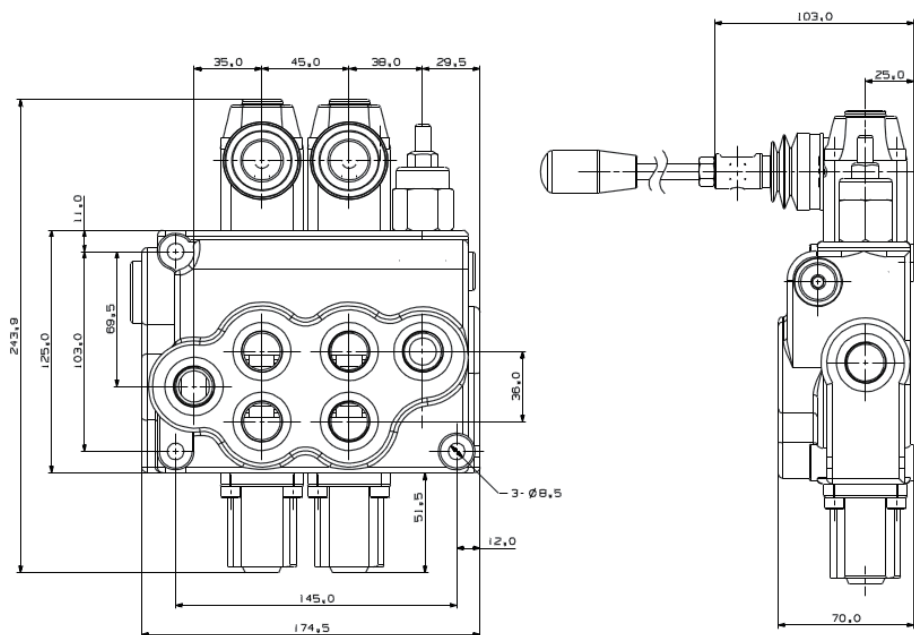

## Dimensions

GDV70-3: 3 Spools Monoblock Valve

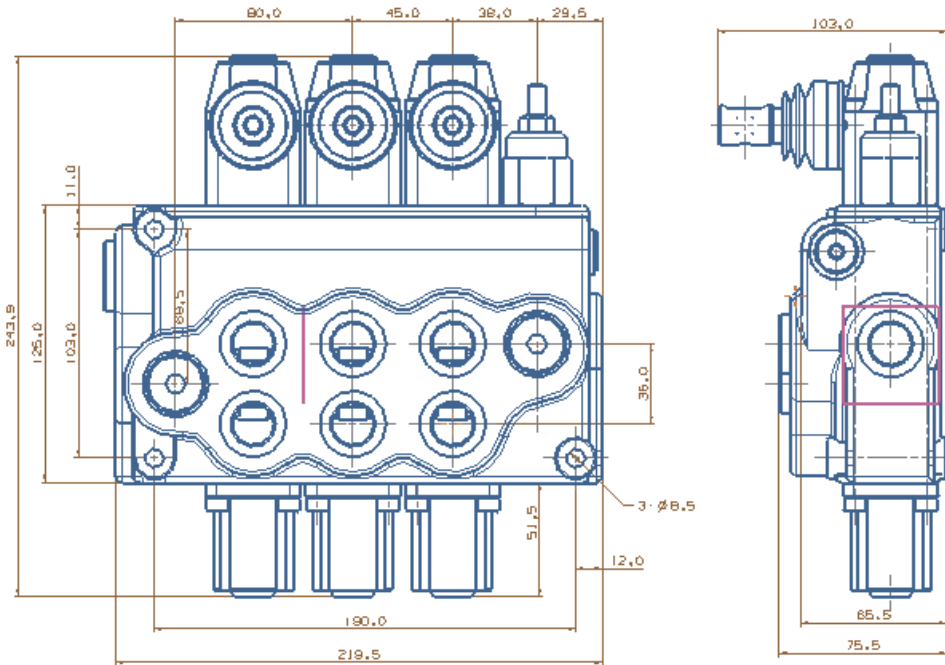

GDV70-4: 4 Spools Monoblock Valve

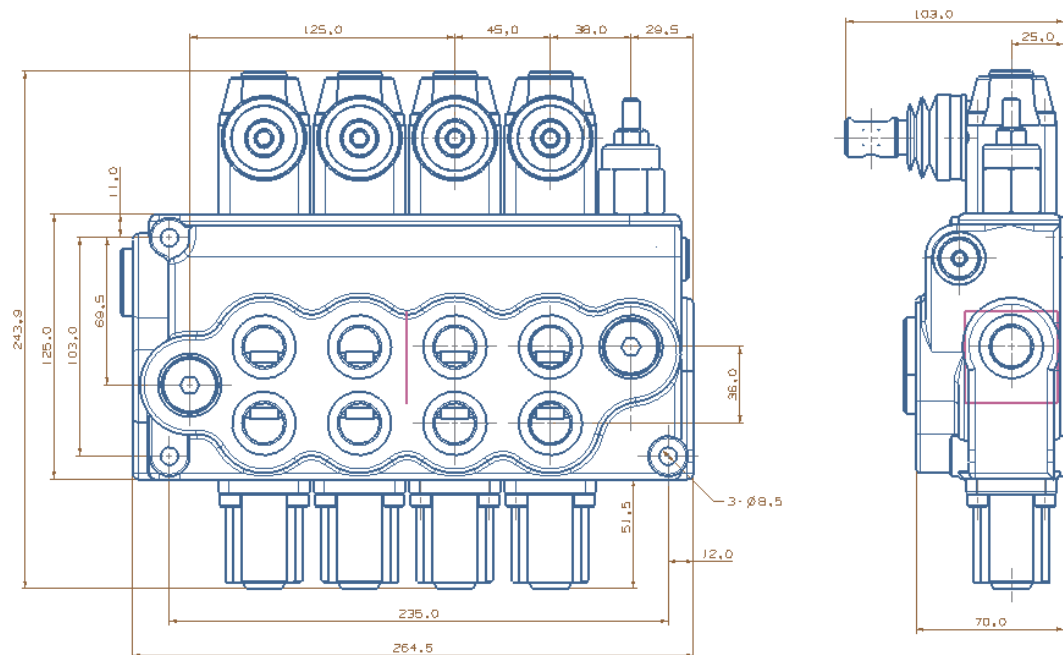

### Inlet Options

Inlet Option Code: P1 (Port at the front)

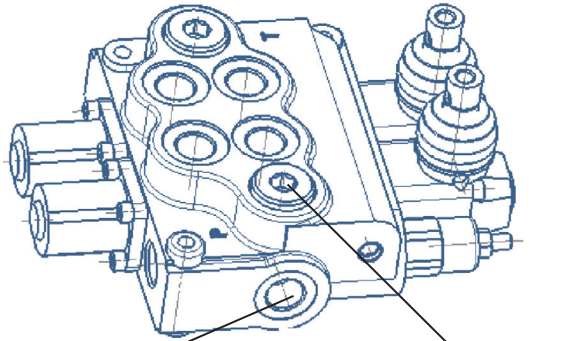

Inlet Port Code: P2 (Port at the top)

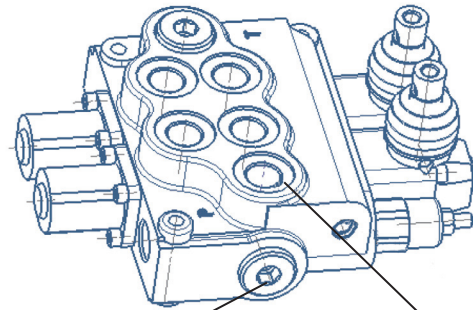

Inlet Port at the front

Port at the top plugged

Port at the front plugged

Inlet port at the top

### Return Port Options

Return Port Option Code: T1 (Return port at the front)

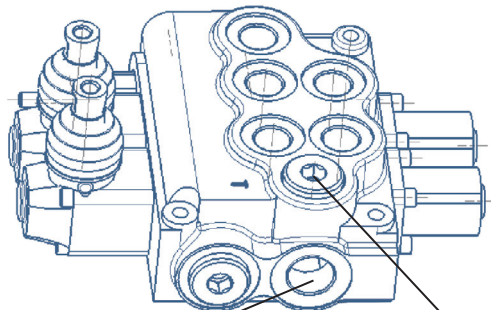

Return Port Option Code: T2 (Return port at the top)

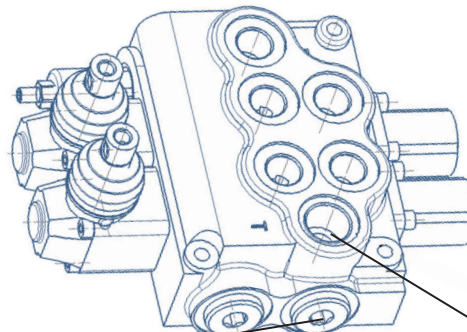

Return port at the front

Port at the top plugged

Port at the front plugged

Return port at the top

### Power Beyond Options

Power Beyond Option Code:

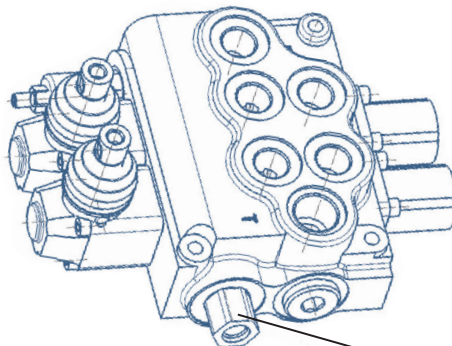

D1 (Pump flow output to a power beyond connector)

D0 (Without power beyond)

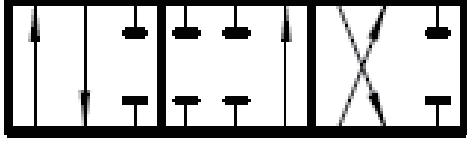
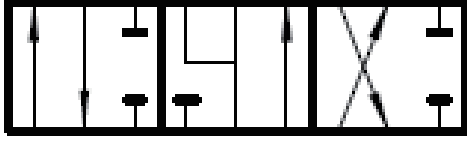
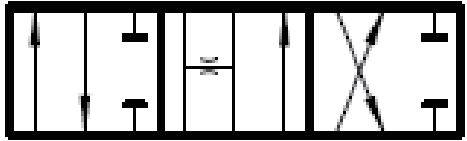
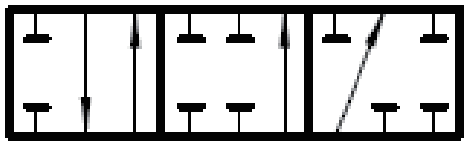

Power beyond connector

## Typical Spool Functions

Spool Code	Spool Type	Functions	Notes
FG1		3-position 4-way At neutral: P, T, A, B are all blocked	Double acting cylinder applications
FG2		3-position 4-way At neutral: P blocked T, A, B connected	Hydraulic motor applications
FG3		3-position 4-way At neutral: P, A, B and T all connected	Hydraulic motor applications
FG4		3-position 3-way At neutral: P, T, A, B all blocked	Single acting cylinder applications
FG5 (not available)		4-position 4-way At neutral: P, T, A and B are all blocked 4th position floating	Double acting cylinder applications
FG6 (not available)		4-position 4-way At neutral: P blocked, T, A and B are connected 4th position floating	Double acting cylinder or hydraulic motor applications

### Drive Options

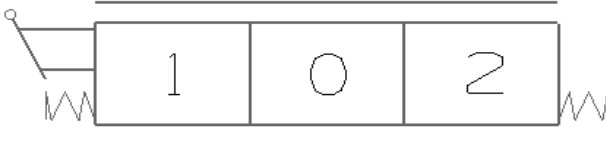
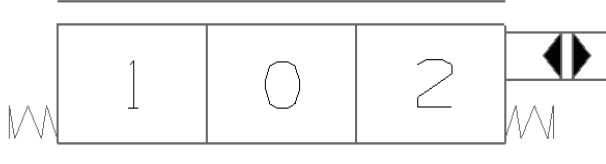
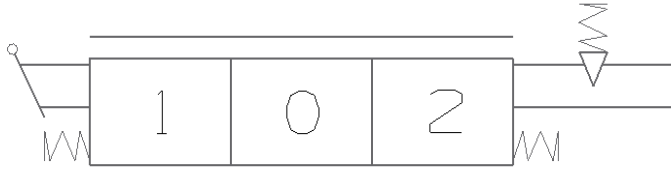
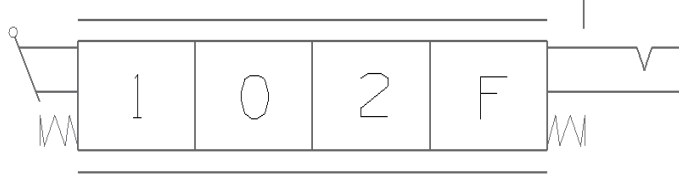
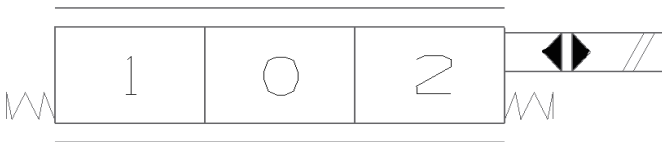
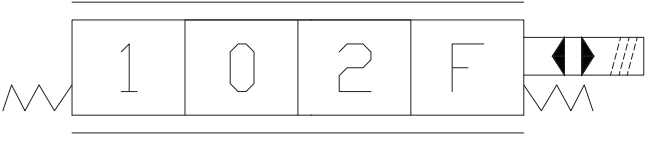
Drive Style Code	Hydraulic Schematic	Functions
KQ1		Standard manual control
KQ2 (not available)		Hydraulic remote
KQ3		Manual control with mechanical detent
KQ4		Manual control with 4th position floating and detent
KQ5 (not available)		Electrical drive(on/off)
KQ6 (not available)		Electrical actuated with floating function

## Ordering Code

GDV70	-*	-P*	/**	-T*	-D*	-O1	-FG*	KQ*	-DC/**	-AR/**
a	b	c	d	e	f	g	h	i	j	k

Ⓐ Model

Ⓑ Number of spools

Ⓒ Inlet port code

Ⓓ Inlet relief setting(bar)

Ⓔ Return port code

Ⓕ Power beyond

Ⓖ First spool

ⓑ Spool function

FG1, FG2, FG3, FG4, FG5, FG6

Ⓙ Drive code

KQ1, KQ2, KQ3, KQ4, KQ5, KQ6

Ⓚ Electrical option

12VDC, 24VDC, 00=none electrical

Ⓛ Relief settings of the over load relief at A port(bar)

If no relief, input for pressure: 000

-BR/**	-O2	.....
l	m	n

Ⓛ Relief settings of the over load relief at B port(bar)

If no relief, input for pressure: 000

Ⓜ Second spool

Ⓝ .....

## Ordering Example

GDV70	-3	-P1	/210	-T1	-D1	-O1	-FG1	KQ1	-DC/00	-AR/250	-BR/190
a	b	c	d	e	f	g	h	i	j	k	l

- |                                |   |
|--------------------------------|---|
| ⓐ Model                        | ⓑ First spool                             |
| ⓑ Three spools monoblock valve | ⓓ Spool function: O-type                  |
| ⓒ Inlet port at the front      | ⓔ Drive mode: standard manual control     |
| ⓓ Inlet relief setting(210bar) | ⓖ Not electrical                          |
| ⓔ Return port at the front     | ⓗ Port A overload setting pressure 250bar |
| ⓕ Power beyond                 | ⓘ Port B overload setting pressure 190bar |

-O2	-FG2	-KQ5	-DC/24	-AR/000	-BR/000	-O3	-FG2	-KQ2	-DC/00	-AR/220	-BR/000
m	n	o	p	q	r	s	t	u	v	w	x

- |                                 |   |
|---------------------------------|---|
| ⓓ Second spool                  | ⓙ Third spool                             |
| ⓓ Spool function: Y-type        | ⓚ Spool function: Y-type                  |
| ⓖ Drive mode: electrical drive  | ⓜ Drive mode: hydraulic remote            |
| ⓗ 24 VDC                        | ⓞ Not electrical                          |
| ⓙ Port A without overload valve | ⓞ Port A overload setting pressure 220bar |
| ⓚ Port B without overload valve | ⓞ Port B without overload valve           |

## GDV80 Series Monoblock Valves

	47	└ Main Features
Technical Data ┘	47	
	48	└ Performance Data
Basic Operating Principle ┘	49	
	50	└ Hydraulic Schematics
Dimensions ┘	51-53	
	54	└ Inlet Port Options
Return Port Options ┘	54	
	54	└ Power Beyond Options
Typical Spool Functions ┘	55	
	56	└ Drive Options
Ordering Code ┘	57	
	58	└ Ordering Example



## GDV80 Series Monoblock Valves

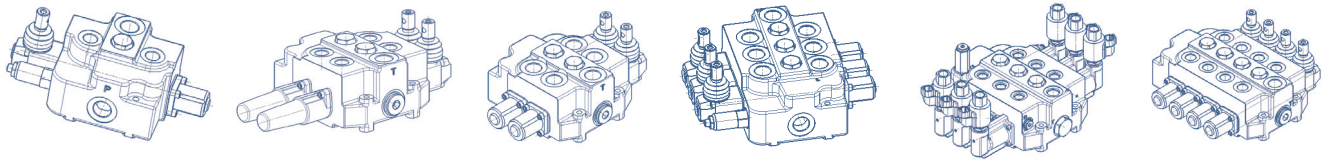

### Main Features

- Cast iron monoblock body.
- Spring cap, mechanical detent cap, as well as electric or hydraulic pilot controlled module body are made by cast aluminum or die cast aluminum.
- Parallel circuit. Each spool has its own load check valve.
- Provides different drive modules (electrical drive, hydraulic remote, manually control, wire driving).
- Provides power beyond port.
- Can be modified to a close circuit.
- Provides different spool functions to be used for controlling double acting cylinder , single acting cylinders, hydraulic motors.
- Provides machanical detent with adjustable detent force.
- Provides excellent flow characteristics and small operating force.
- Can be proportionally controlled (without pressure compensation);
- Can be made with 1-6 spools.

### Technical Data

Rated flow rate	80 L/min	With NBR seals	-20°C - 80°C
Maximum flow rate	100 L/min	With FKM seals	-20°C - 100°C
Maximum pressure at P port	310 bar	Spool stroke(1, 2 position)	+7/-7mm
Maximum pressure at A/B port	310 bar	With floating function(1, 2 , F position)	+7/-7 -9mm
Maximum pressure at T port	25 bar	Recommend hydraulic oil viscosity range	15-75mm <sup>2</sup> /s
Internal leakage(@70 bar)	A/B to T 30-35 cc/min	Recommend temperature range	-40°C - 60°C

Solenoid can be either 12 VDC or 24 VDC , corresponding current is 0 - 1.5 or 0 - 0.75 Amp.

## Performance Data

At Neutral, Pressure Drop (P to T)

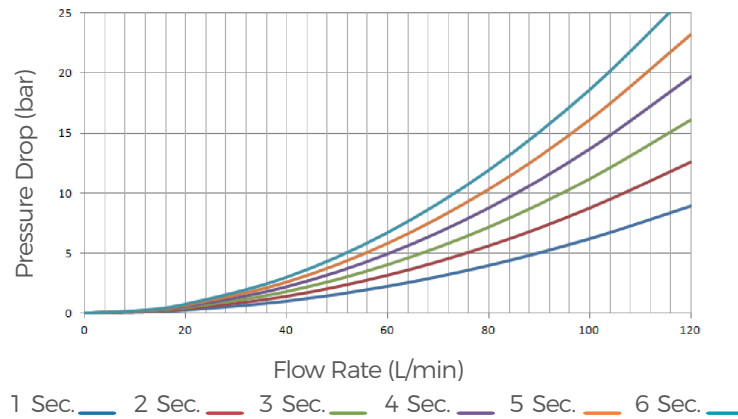

Pressure Drop (P to A/B)

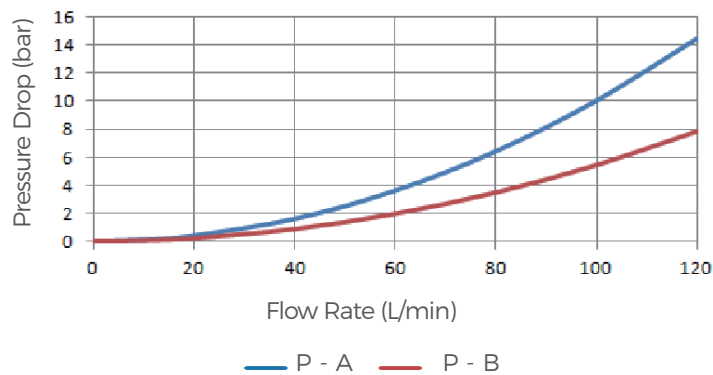

Pressure Drop (A/B to T)

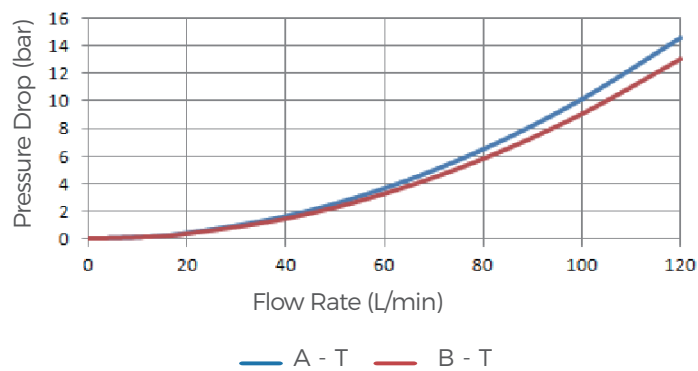

### Basic Operating Principle

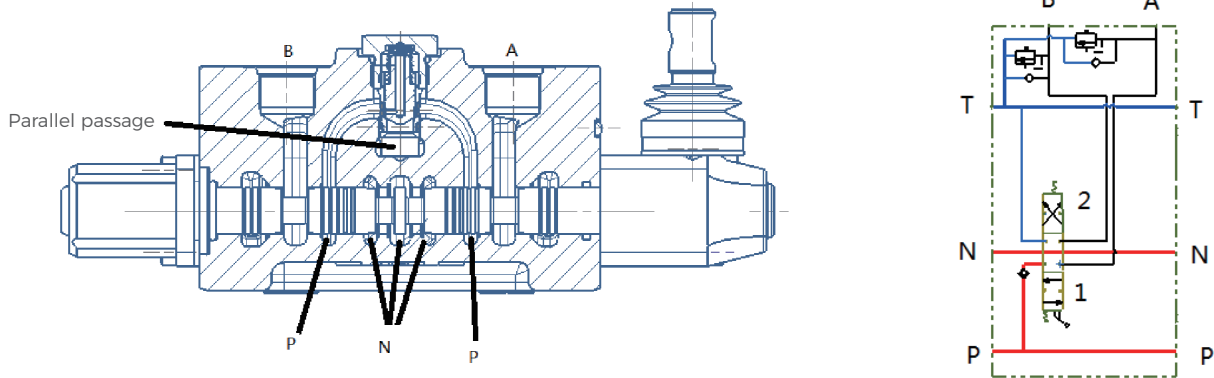

GDV80 series monoblock valve is an open centered 3-position 4-way valve. When spool is in its neutral position, the flow from pump passes through the neutral passage to tank, with very low pressure drop. When one of the spool is moved to 1 or 2 position, the neutral passage is blocked. The flow from pump can only pass through parallel passage to load check valve, then, through the spool port and enter into spool controlled working port A or B.

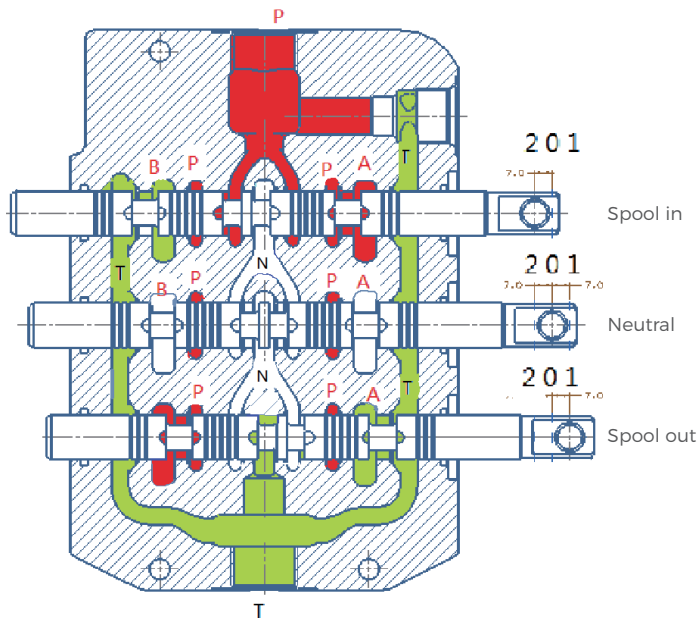

For multi-spool monoblock valves, if one of the spools is in 1 or 2 position, then there is no flow in its downstream spool's neutral passage. The main throttle occurs on the valve opening between bridge passage and spool. The operator can control more than one spool, but the flow rate for each controlled spool is dependent on the load.

## Hydraulic Schematics

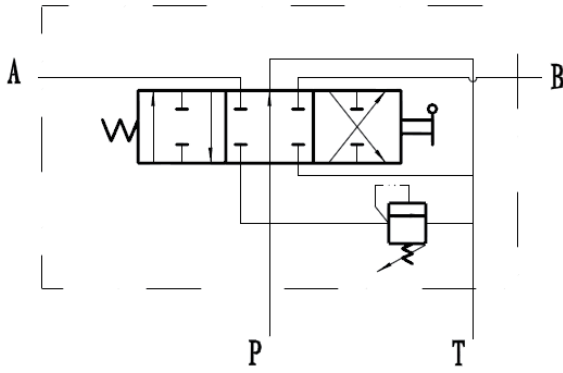

GDV80-1

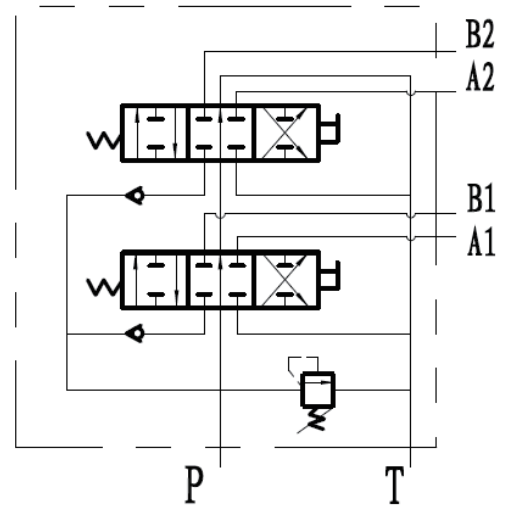

GDV80-2

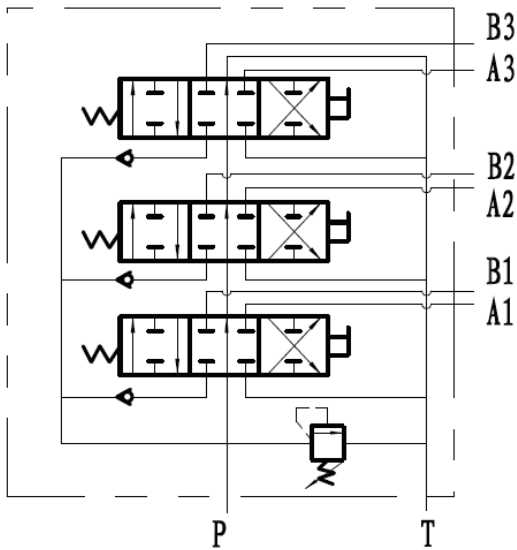

GDV80-3

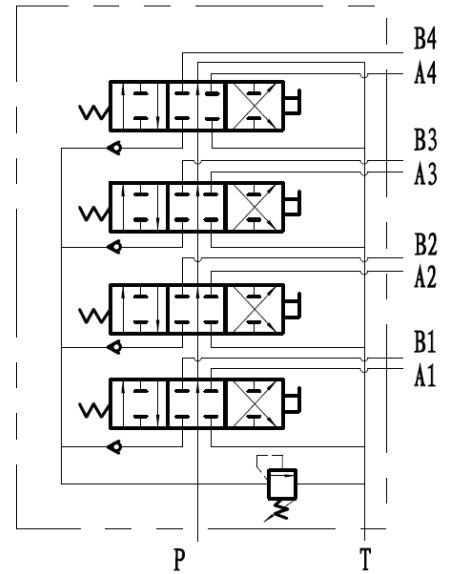

GDV80-4

## Dimensions

### GDV80-1: 1 Spool Monoblock Valve

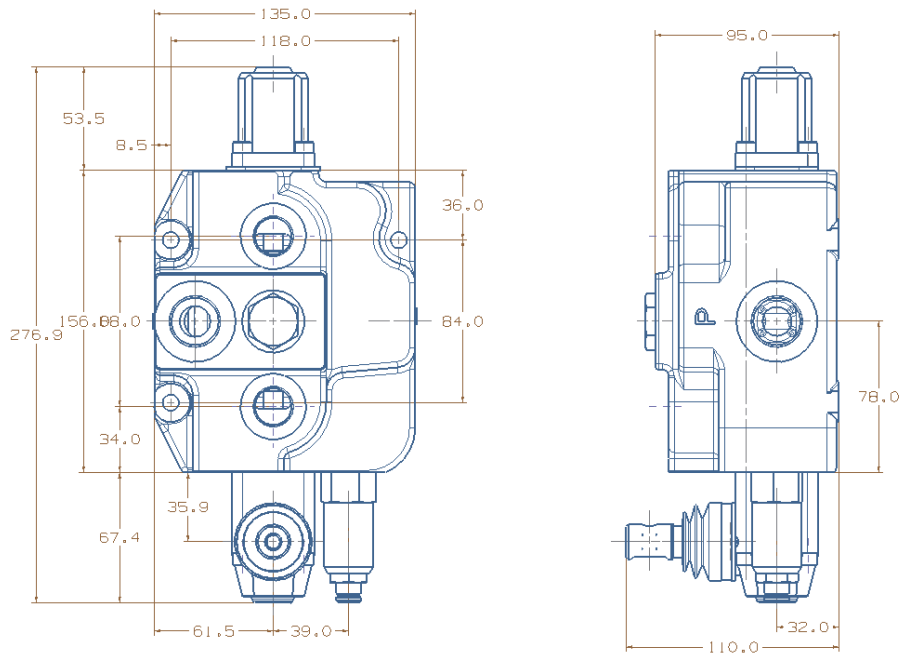

### GDV80-2: 2 Spools Monoblock Valve

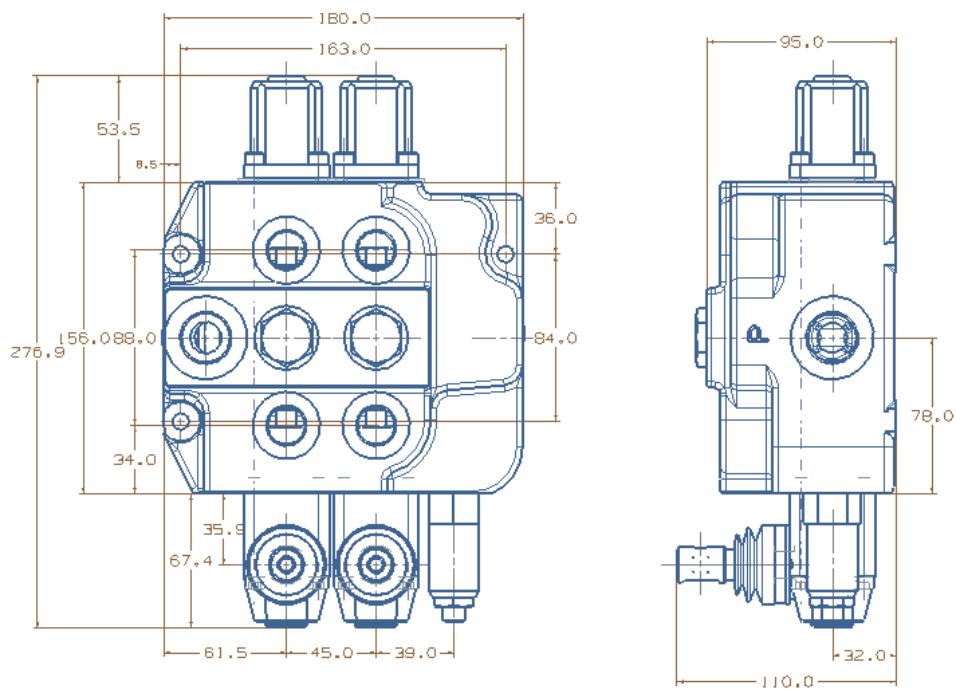

## Dimensions

### GDV80-3: 3 Spools Monoblock Valve

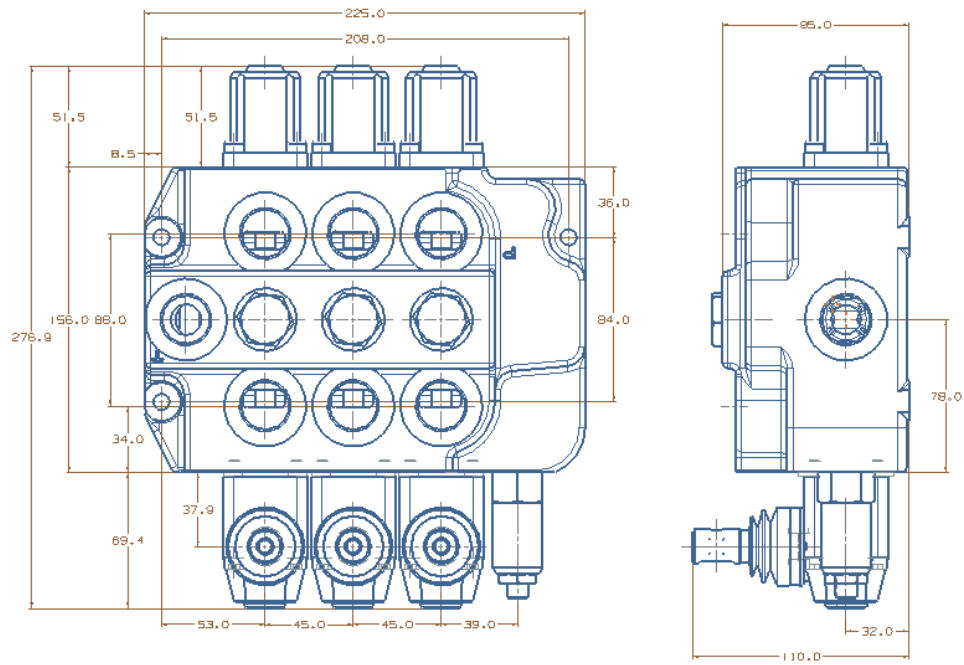

### GDV80-4: 4 Spools Monoblock Valve

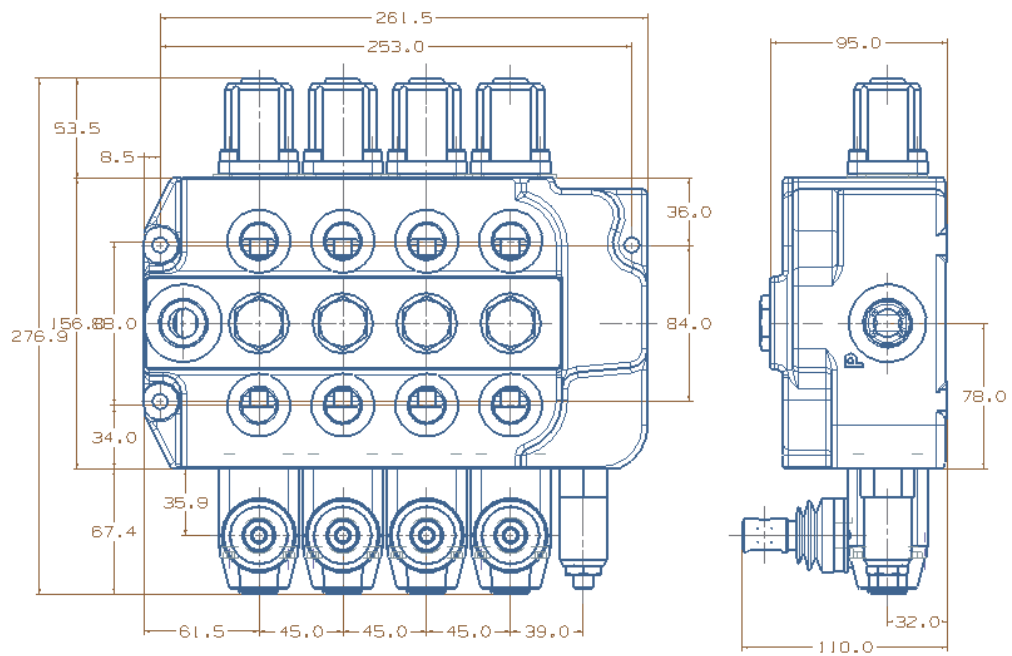

## Dimensions

### Electrical Drive

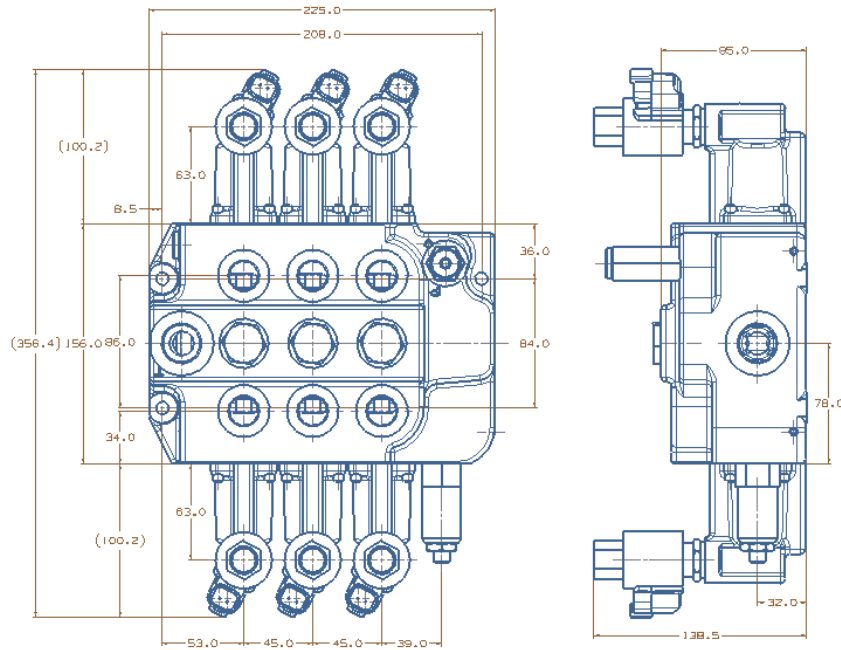

### Hydraulic Remote

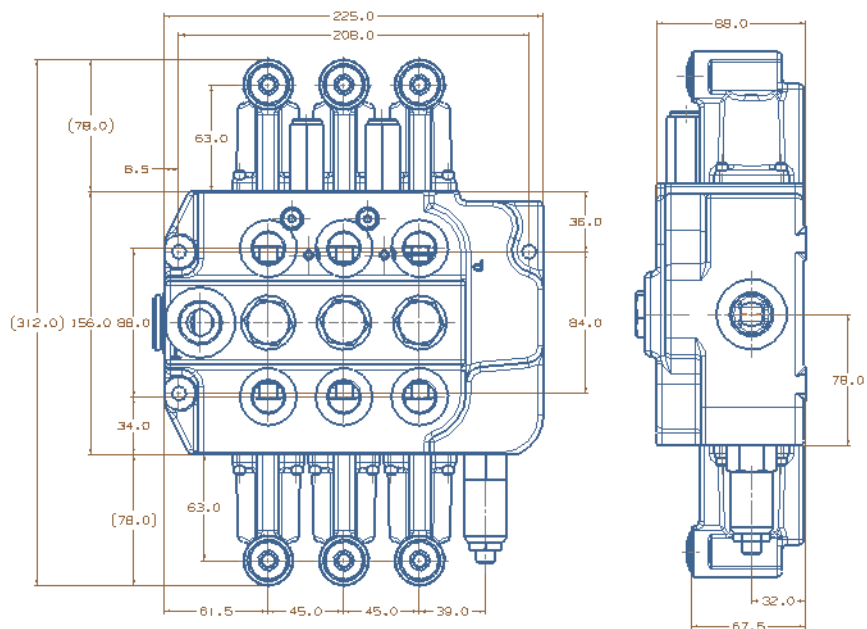

## Inlet Port Options

Inlet Option Code: P1 (Inlet port at the front)

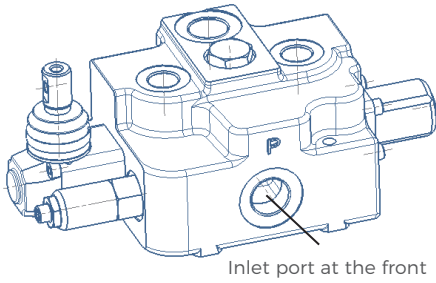

Inlet Port Option Code: P2 (Inlet port at the top)

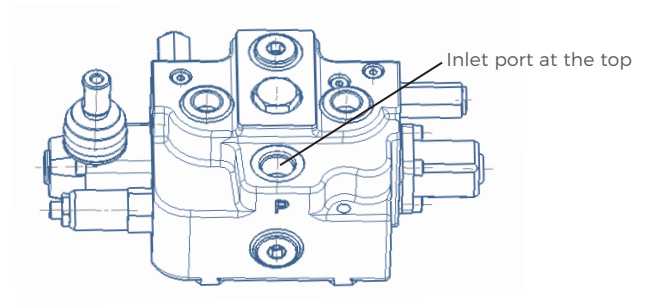

## Return Port Options

Return Port Option Code: T1 (Return port at the front)

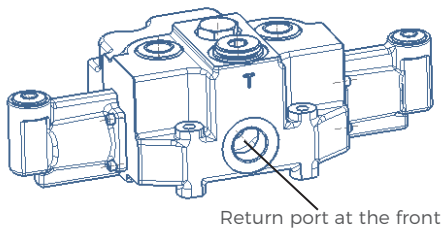

Return Port Option Code: T2 (Return port at the top)

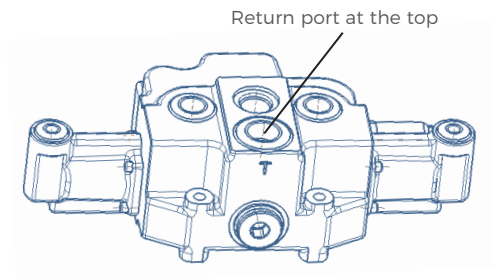

## Power Beyond Options

Power Beyond Port Option Code:

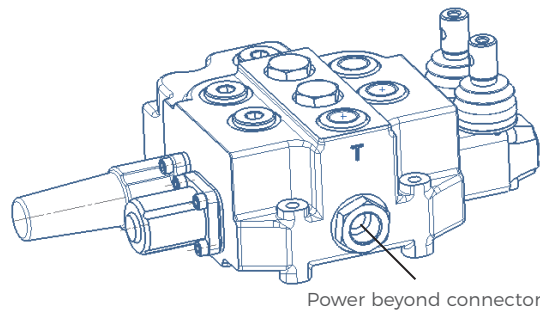

D1 (Pump flow output to a power beyond connector)

D0 (Without power beyond)



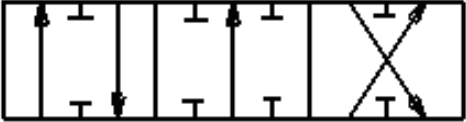
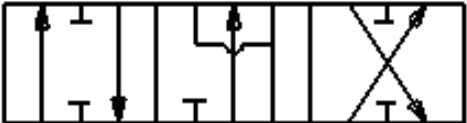
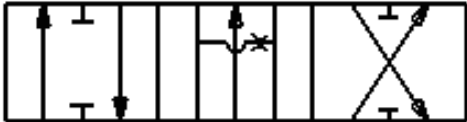
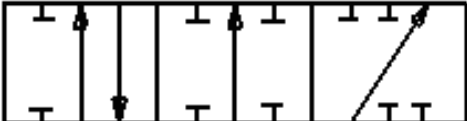
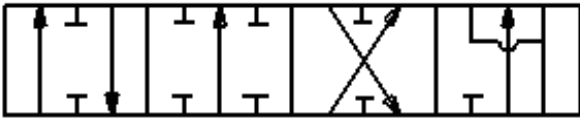

## Typical Spool Functions

Spool Code	Spool Type	Function	Notes
FG1		3-position 4-way At neutral: P, T, A, B are all blocked	Double acting cylinder applications
FG2		3-position 4-way At neutral: P blocked, T, A, B connected	Hydraulic motor applications
FG3		3-position 4-way At neutral: P, A, B and T all connected	Hydraulic motor applications
FG4		3-position 3-way At neutral: P, T, A, B all blocked	Single acting cylinder applications
FG5		4-position 4-way At neutral: P, T, A, and B are all blocked 4th position floating	Double acting cylinder applications
FG6		4-position 4-way At neutral: P blocked, T, A and B are connected 4th position floating	Double acting cylinder or hydraulic motor applications

## Drive Options

Drive Style Code	Hydraulic Schematic	Functions
KQ1		Standard manual control
KQ2		Hydraulic remote
KQ3		Manual control with mechanical detent
KQ4		Manual control with 4th position floating and detent
KQ5		Electrical drive(on/off)
KQ6		Electrical actuated with floating function

## Ordering Code

GDV80	-*	-P*	/***	-T*	-D*	-O1	-FG*	KQ*	-DC/**	-AR/***
a	b	c	d	e	f	g	h	i	j	k

- |  |  |
|--|--|
| <ul style="list-style-type: none"> <li>Ⓐ Model</li> <li>Ⓑ Number of spools</li> <li>Ⓒ Inlet port code</li> <li>Ⓓ Inlet relief setting(bar)</li> <li>Ⓔ Return port code</li> <li>Ⓕ Power beyond</li> <li>Ⓖ First spool</li> </ul> | <ul style="list-style-type: none"> <li>Ⓗ Spool function<br/>FG1, FG2, FG3, FG4, FG5, FG6</li> <li>Ⓘ Drive code<br/>KQ1, KQ2, KQ3, KQ4, KQ5, KQ6</li> <li>⓵ Electrical option<br/>12VDC, 24VDC, 00=none electrical</li> <li>Ⓚ Relief settings of the over load relief at A port(bar)<br/>If no relief, input for pressure: 000</li> </ul> |
|--|--|

-BR/***	-O2	.....
l	m	n

- Ⓛ Relief settings of the over load relief at B port(bar)  
If no relief, input for pressure: 000
- Ⓜ Second spool
- Ⓝ .....

## Ordering Example

GDV80	-3	-P1	/210	-T1	-D1	-O1	-FG1	KQ1	-DC/00	-AR/250	-BR/190
a	b	c	d	e	f	g	h	i	j	k	l

- |                                |   |
|--------------------------------|---|
| Ⓐ Model                        | Ⓔ First spool                             |
| Ⓑ Three spools monoblock valve | Ⓕ Spool function: O-type                  |
| Ⓒ Inlet port at the front      | Ⓖ Drive mode: standard manual control     |
| Ⓓ Inlet relief setting(210bar) | Ⓗ Not electrical                          |
| Ⓔ Return port at the front     | Ⓚ Port A overload setting pressure 250bar |
| Ⓕ Power beyond                 | Ⓛ Port B overload setting pressure 190bar |

-O2	-FG2	-KQ5	-DC/24	-AR/000	-BR/000	-O3	-FG2	-KQ2	-DC/00	-AR/220	-BR/000
m	n	o	p	q	r	s	t	u	v	w	x

- |                                 |   |
|---------------------------------|---|
| Ⓜ Second spool                  | Ⓢ Third spool                             |
| Ⓝ Spool function: Y-type        | Ⓣ Spool function: Y-type                  |
| Ⓞ Drive mode: electrical drive  | Ⓤ Drive mode: hydraulic remote            |
| Ⓟ 24VDC                         | Ⓡ Not electrical                          |
| Ⓠ Port A without overload valve | Ⓦ Port A overload setting pressure 220bar |
| Ⓡ Port B without overload valve | Ⓡ Port B without overload valve           |

## GDV120 Series Monoblock Valves

	60	└ Main Features
Technical Data ┘	60	
	61	└ Performance Data
Basic Operating Principle ┘	62	
	63	└ Dimensions
Inlet Port Options ┘	64	
	64	└ Return Port Options
Typical Spool Functions ┘	65	
	66	└ Drive Options
Ordering Code ┘	67	
	67	└ Ordering Example

## GDV120 Series Monoblock Valves

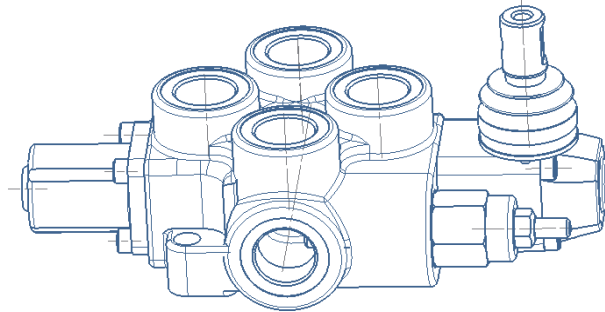

### Main Features

- Cast iron monoblock body.
- Spring cap, mechanical detent cap, as well as electric or hydraulic pilot controlled module body are made by cast aluminum or die cast aluminum.
- Provides mechanical detent.
- Provides power beyond port.
- Provides different spool functions to be used for controlling double acting cylinders, single acting cylinders, hydraulic motors.
- Provides excellent flow characteristics and small operating force.
- Can be made with 1-4 spools (now we can offer 1 spool).

### Technical Data

Rated flow rate	120 L/min	With NBR seals	-20°C- 80°C
Maximum flow rate	130 L/min	With FKM seals	-20°C- 100°C
Maximum pressure at P port	310 bar	Spool stroke(1, 2 position)	+7/-7mm
Maximum pressure at A/B port	310 bar	With floating function(1, 2 , F position)	+7/-7 -9mm
Maximum pressure at T port	25 bar	Recommend hydraulic oil viscosity range	15-75mm <sup>2</sup> /s
Internal leakage(@70 bar)	A/B to T 30-35cc/min	Recommend temperature range	-40°C- 60°C

Solenoid can be either 12 VDC or 24 VDC , corresponding current is 0 - 1.5 or 0 - 0.75 Amp.

### Performance Data

At Neutral, Pressure Drop (P to T)

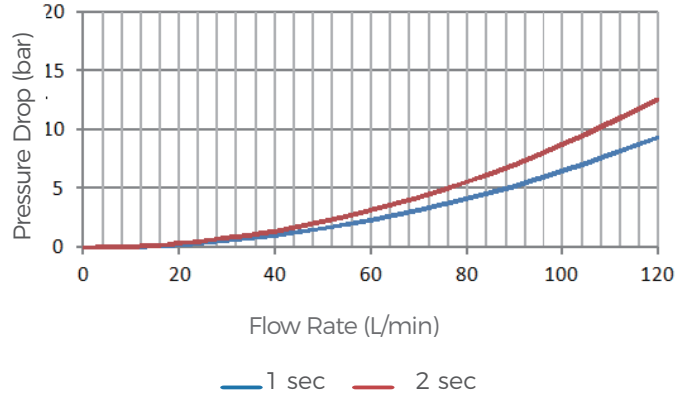

Pressure Drop (P to A/B)

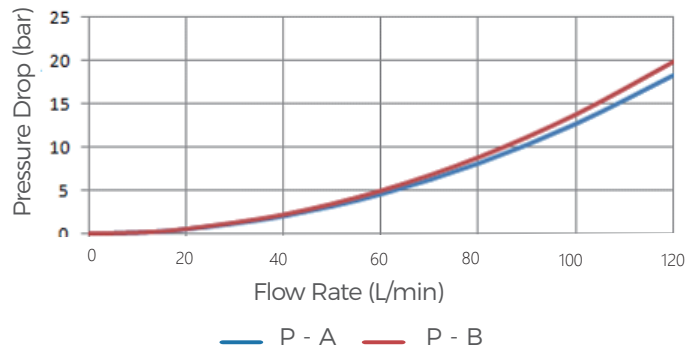

Pressure Drop (A/B to T)

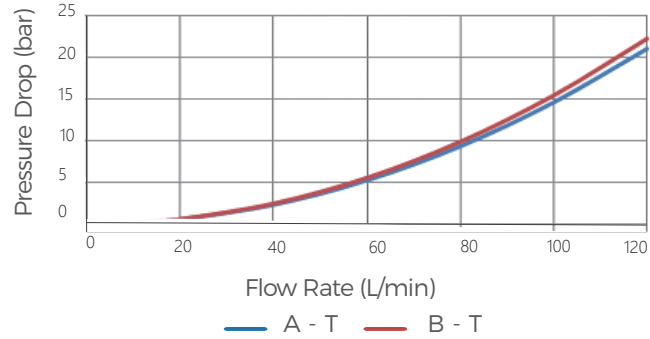

## Basic Operating Principle

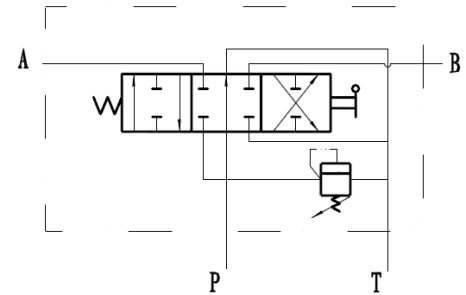
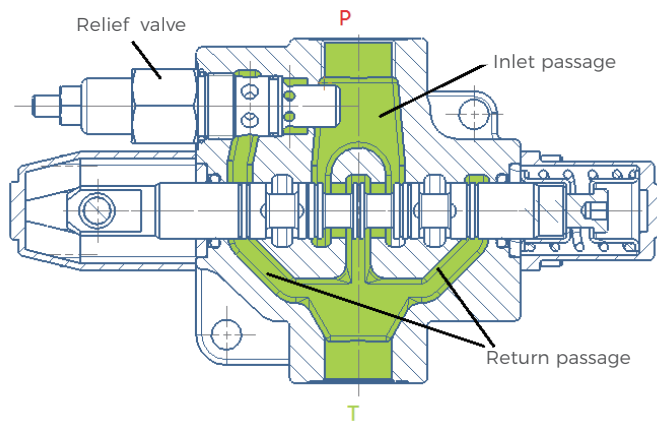

GDV120 series monoblock valve is an open centered 3-position 4-way valve. When spool is in its neutral position, the flow from pump passes through the neutral passage to tank, with very low pressure drop.

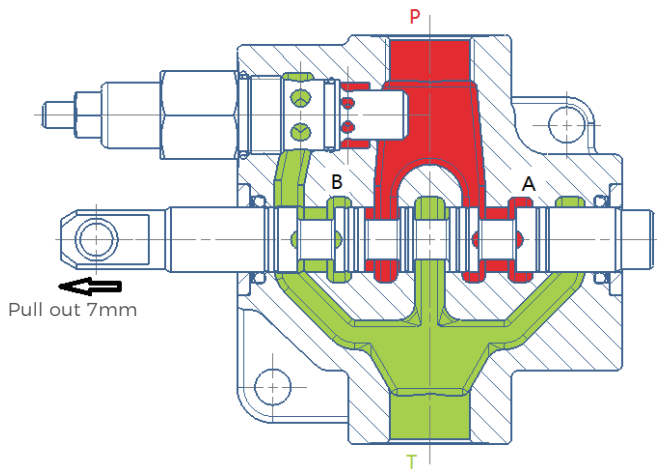

When spool is pulled out 7 mm, the neutral passage is blocked. Flow from pump passes through the spool opening on the right side to work port A. At the same time, the flow from port B passes to return passage, then to tank, through the spool opening on the left side of the spool.

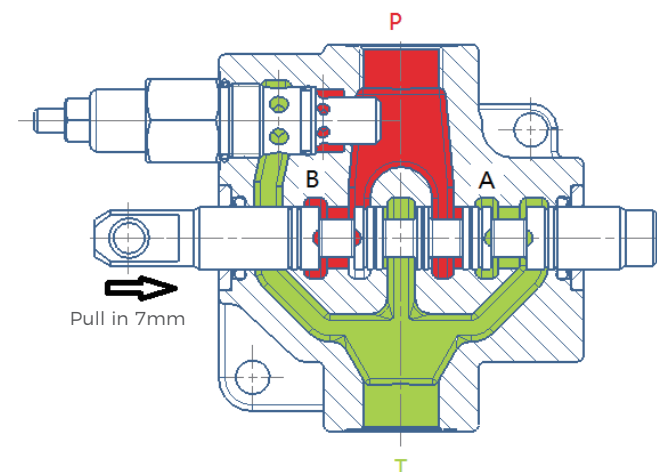

When spool is pushed in 7 mm, the neutral passage is blocked. Flow from pump passes through the spool opening on the left side to work port B. At the same time, the flow from port A passes to return passage, then to tank, through the spool opening on the right side of the spool.



## Dimension

### GDV120-1: 1 Spool Monoblock Valve

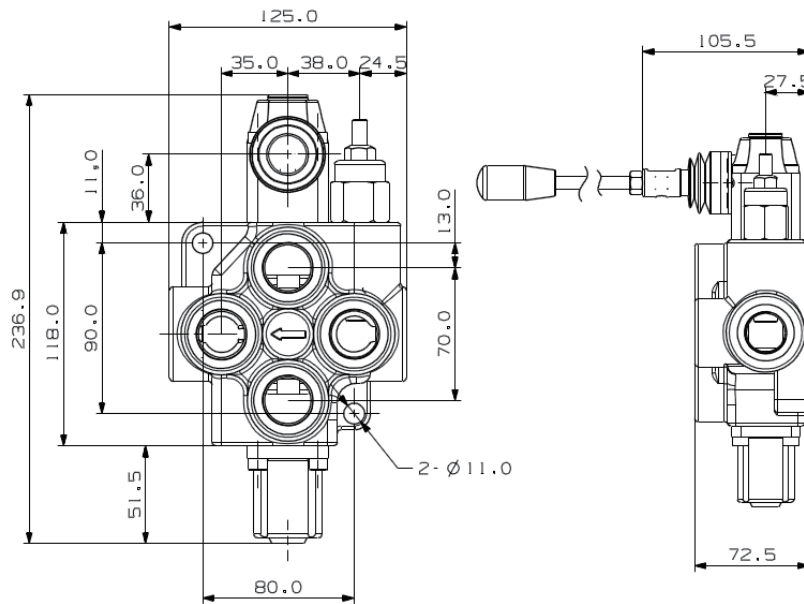

## Inlet Port Options

Inlet Option Code: P1(Inlet port at the front)

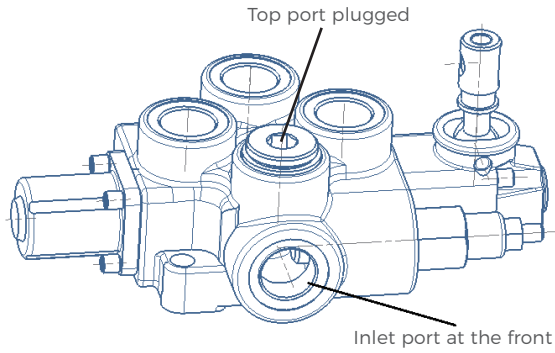

Inlet Port Option Code: P2(Inlet port at the top)

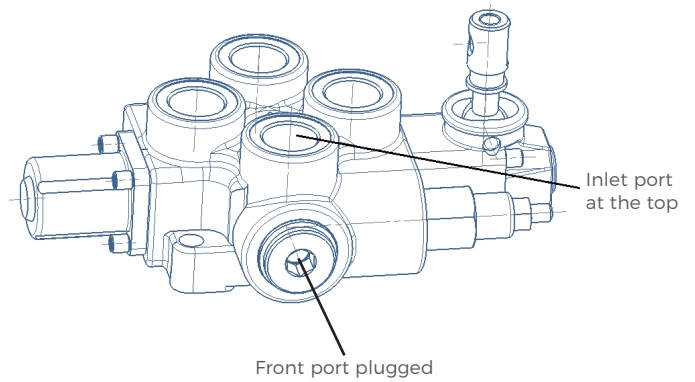

## Return Port Options

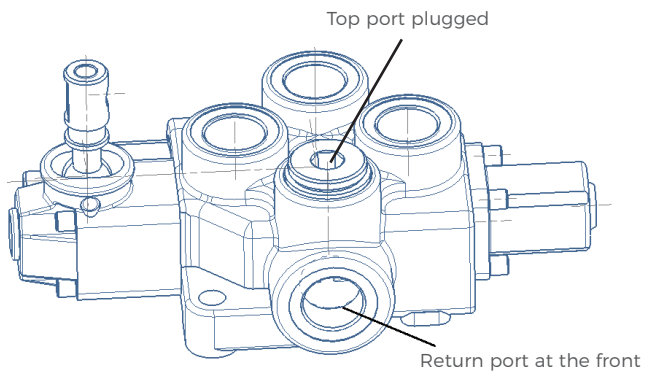

Return Port Option Code: T1(Return port at the front)

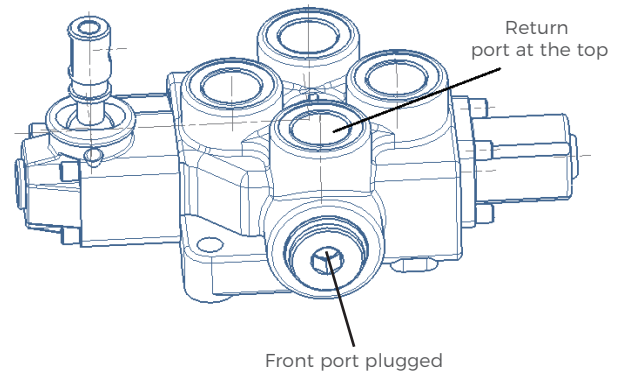

Return Port Option Code: T2(Return port at the top)

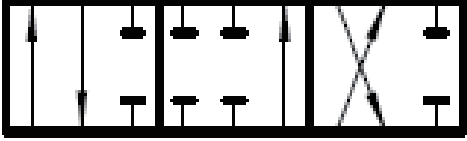
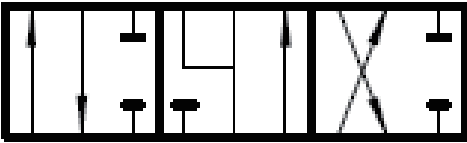
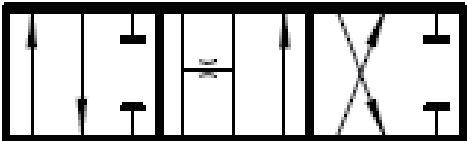
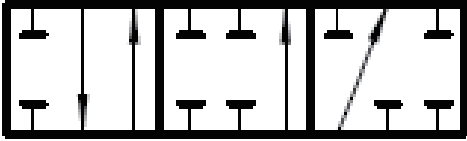

## Typical Spool Functions

Spool Code	Spool Type	Functions	Notes
FG1		3-position 4-way At neutral: P, T, A, B are all blocked	Double acting cylinder applications
FG2		3-position 4-way At neutral: P blocked, T, A, B connected	Hydraulic motor applications
FG3		3-position 4-way At neutral: P, A, B and T all connected	Hydraulic motor applications
FG4		3-position 3-way At neutral: P, T, A, B all blocked	Single acting cylinder applications
FG5 (not available)		4-position 4-way At neutral: P, T, A and B are all blocked 4th position floating	Double acting cylinder applications
FG6 (not available)		4-position 4-way At neutral: P blocked, T, A and B are connected 4th position floating	Double acting cylinder or hydraulic motor applications

## Drive Options

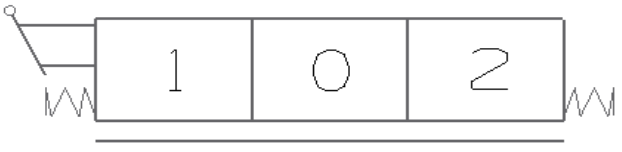
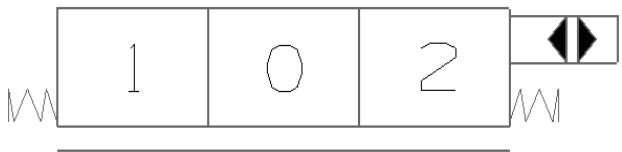
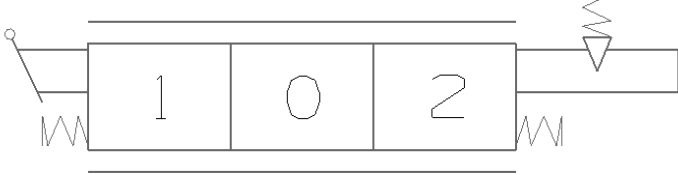
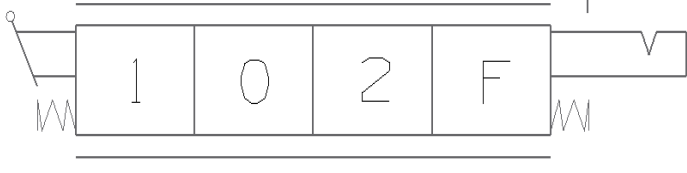
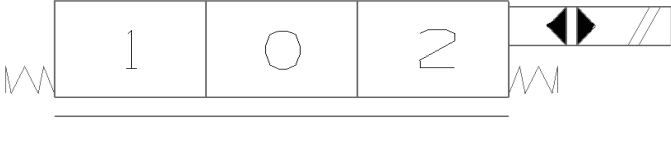
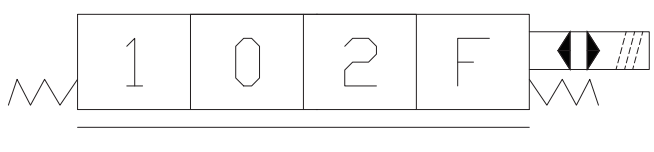
Drive Style Code	Hydraulic Schematic	Functions
KQ1		Standard manual control
KQ2 (not available)		Hydraulic remote
KQ3		Manual control with mechanical detent
KQ4		Manual control with 4th position floating and detent
KQ5 (not available)		Electrical drive(on/off)
KQ6 (not available)		Electrical actuated with floating function



## Ordering Code

GDV120	-P*	/**	-T*	-FG*	KQ*
a	b	c	d	e	f

- Ⓐ Model
- Ⓑ Inlet port code
- Ⓒ Inlet relief setting(bar)
- Ⓓ Return port code
- Ⓔ Spool function  
FG1, FG2, FG3, FG4, FG5, FG6
- Ⓕ Drive code  
KQ1, KQ2, KQ3, KQ4, KQ5, KQ6

## Ordering Example

GDV120	-P1	/210	-T1	-FG1	KQ1
a	b	c	d	e	f

- Ⓐ Model
- Ⓑ Inlet port at the front
- Ⓒ Inlet relief setting(210bar)
- Ⓓ Return port at the front
- Ⓔ Spool function: O-type
- Ⓕ Drive code: manual control

## GDV160 Series Monoblock Valves

	69	└ Main Features
Technical Data ┘	69	
	70	└ Performance Data
Basic Operating Principle ┘	71	
	72	└ Dimensions
Inlet Port Options ┘	73	
	73	└ Return Port Options
Power Beyond Options ┘	73	
	74	└ Typical Spool Functions
Drive Options ┘	75	
	76	└ Ordering Code
Ordering Example ┘	76	

## GDV160 Series Monoblock Valves

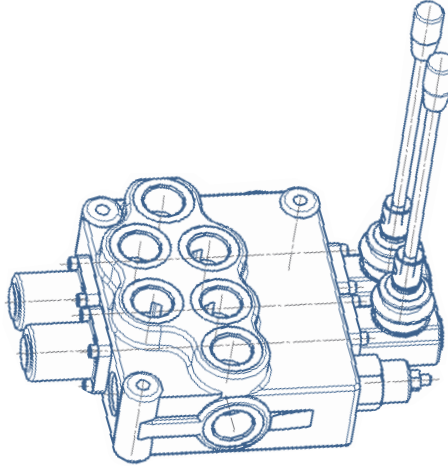

### Main Features

- Cast iron monoblock valve body.
- Spring cap and mechanical detent cap are made in die cast aluminum.
- Parallel circuit. Each spool has its own load check valve.
- Provides different drive modules (electrical, hydraulic remote, manually control, wire driving).
- Provides power beyond port.
- Provides mechanical detent.
- Provides different spool functions to be used for controlling double acting cylinders, single acting cylinders, hydraulic motors.
- Provides small operating force and excellent flow characteristics.
- Can be made with 1-4 spools (now we can offer 2 spools).

### Technical Data

Rated flow rate	160 L/min	With NBR seals	-20°C- 80°C
Maximum flow rate	170 L/min	With FKM seals	-20°C- 100°C
Maximum pressure at P port	310 bar	Spool stroke(1, 2 position)	+7/-7mm
Maximum pressure at A/B port	310 bar	With floating function(1, 2, F position)	+7/-7 -9mm
Maximum pressure at T port	25 bar	Recommend hydraulic oil viscosity range	15-75mm <sup>2</sup> /s
Internal leakage(@70 bar)	A/B to T 30-35cc/min	Recommend temperature range	-40°C- 60°C

Solenoid can be either 12 VDC or 24 VDC, corresponding current is 0 - 1.5 or 0 - 0.75 Amp.

## Performance Data

At Neutral, Pressure Drop (P to T)

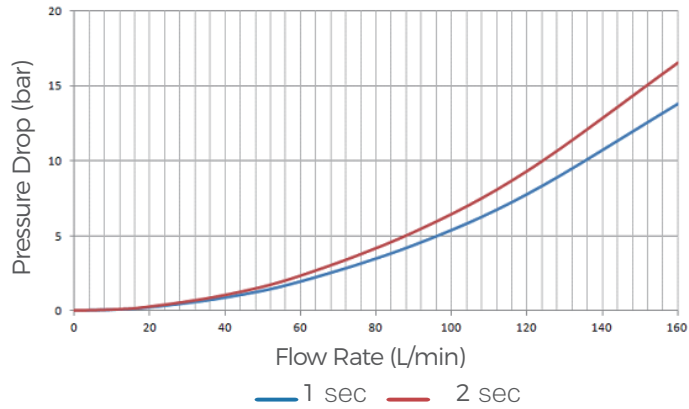

Pressure Drop (P to A/B)

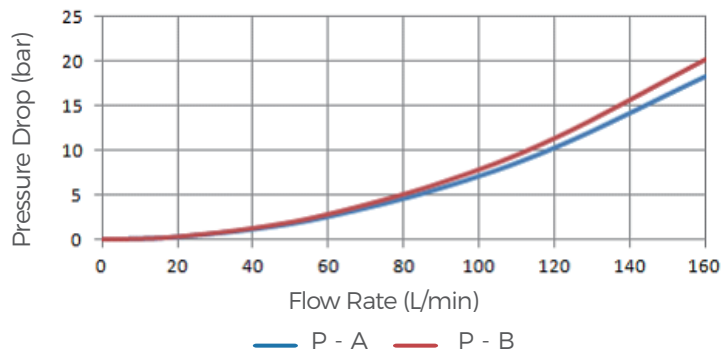

Pressure Drop (A/B to T)

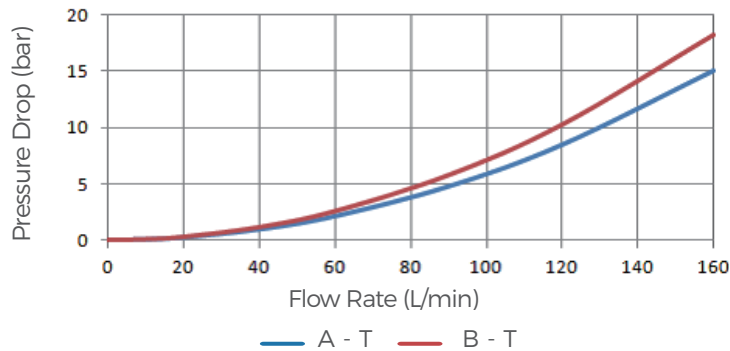



### Basic Operating Principle

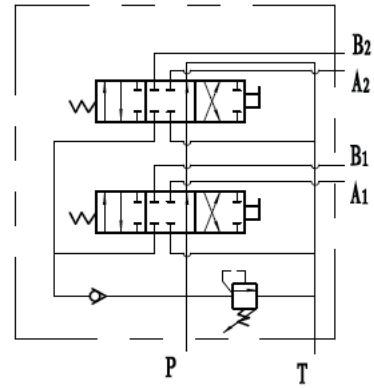
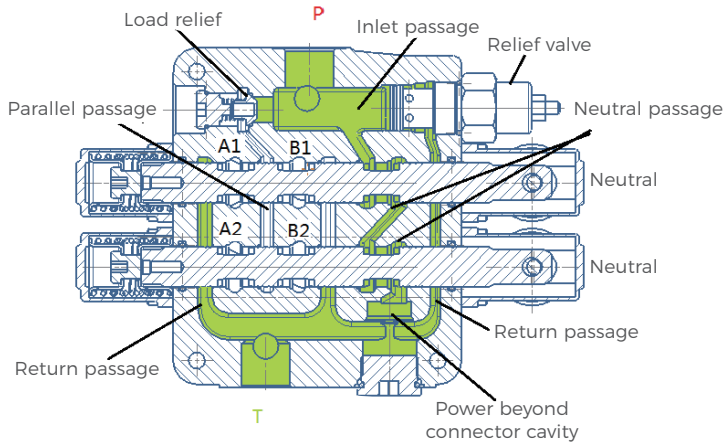

GDV160 series monoblock valve is an open centered 3-position 4-way valve. When spool is in its neutral position, the flow from pump passes through the neutral passage to tank, with very low pressure drop. When one of the spool is moved to 1 or 2 position, the neutral passage is blocked. The flow from pump can only pass through load check valve to parallel passage, then, through spool opening to work port A or B.

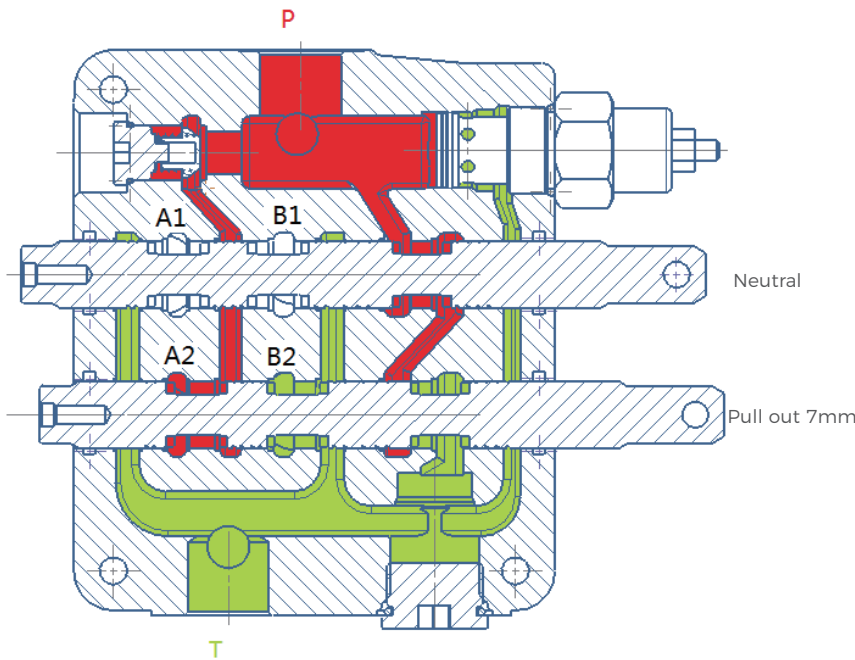

AS shown in the picture, the first spool is in neutral position, flow from pump flows to parallel passage through the load check valve to supply flow to two spools. Because the second spool is pulled out 7mm, the second spool opening between parallel passage to A2 port allows flow to enter the A2 port. B2 port connected to return passage. Neutral passage is blocked by second spool.

## Dimensions

### GDV160-2: 2 Spools Monoblock Valve

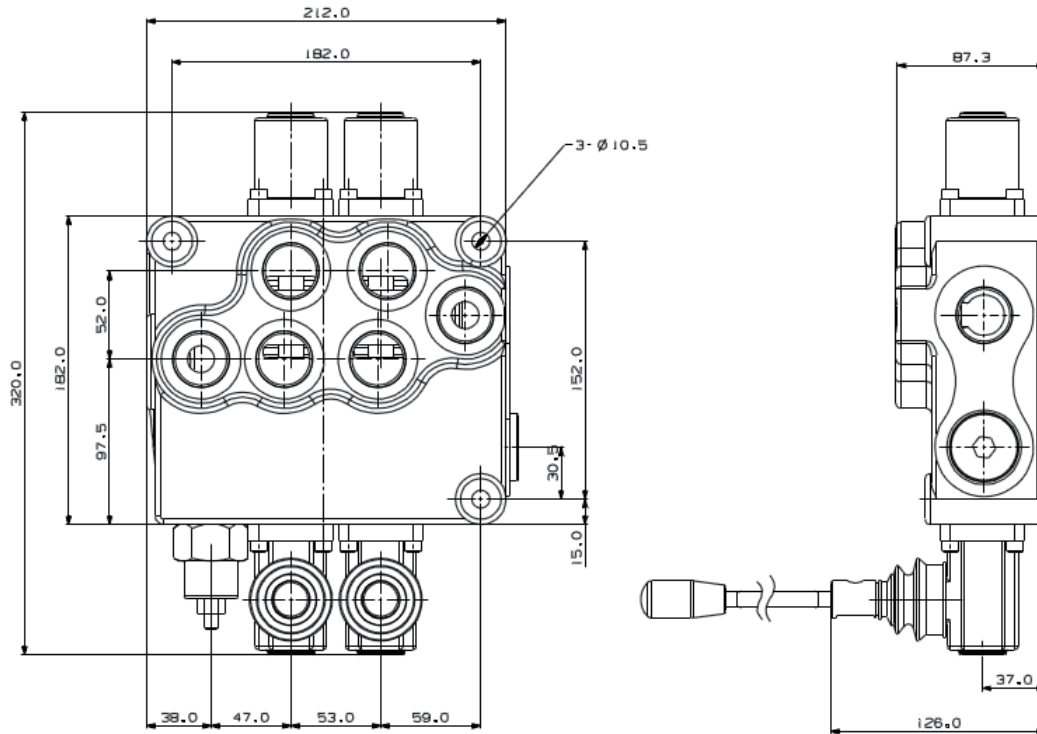

## Inlet Port Options

Inlet Option Code: P1 (Inlet port at the front)

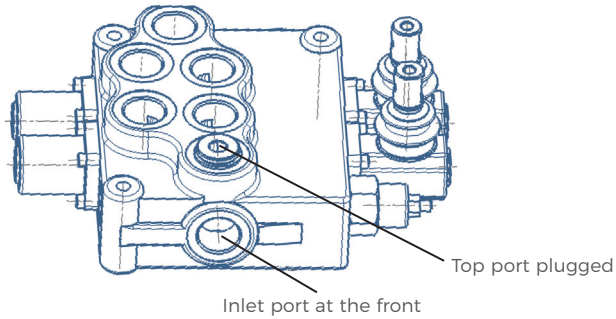

Inlet Port Option Code: P2 (Inlet port at the top)

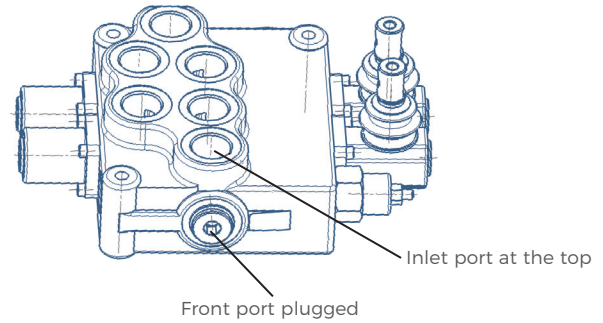

## Return Port Options

Return Port Option Code: T1 (Return port at the front)

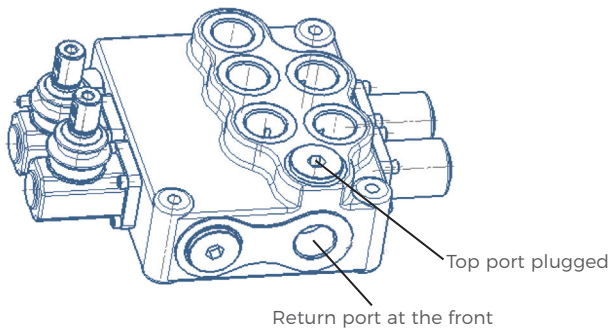

Return Port Option Code: T2 (Return port at the top)

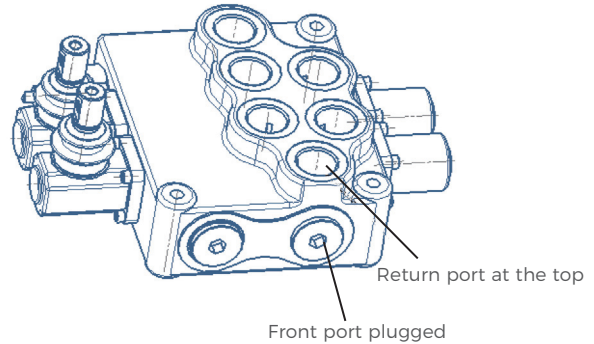

## Power Beyond Options



Power Beyond Option Code:

D1 (Pump flow output to a power beyond connector)

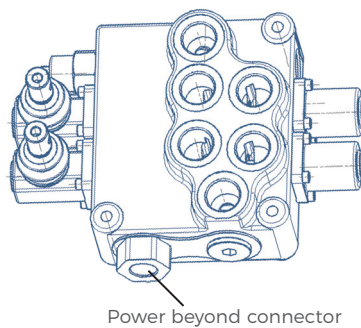
D0 (Without power beyond)

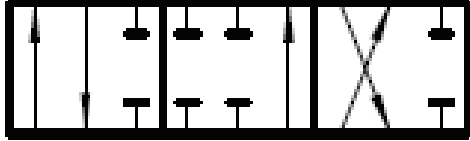
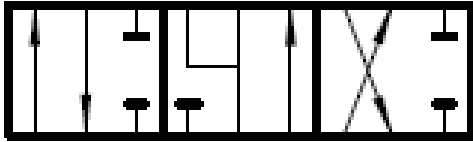
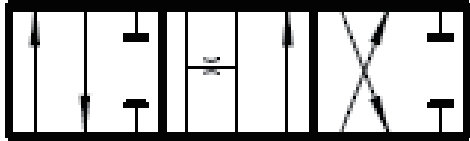
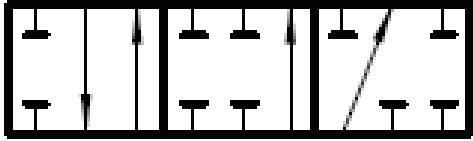

### Typical Spool Functions

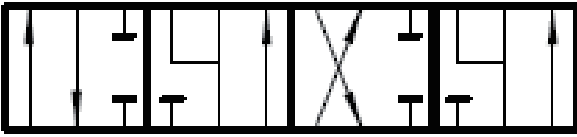
Spool Code	Spool Type	Functions	Notes
FG1		3-position 4-way At neutral: P, T, A, B are all blocked	Double acting cylinder applications
FG2		3-position 4-way At neutral: P blocked, T, A, B connected	Hydraulic motor applications
FG3		3-position 4-way At neutral: P, A, B and T all connected	Hydraulic motor applications
FG4		3-position 3-way At neutral: P, T, A, B all blocked	Single acting cylinder applications
FG5 (not available)		4-position 4-way At neutral: P, T, A, and B are all blocked 4th position floating	Double acting cylinder applications
FG6 (not available)		4-position 4-way At neutral: P blocked, T, A and B are connected 4th position floating	Double acting cylinder or hydraulic motor applications

## Drive Options

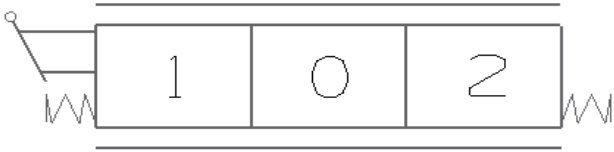
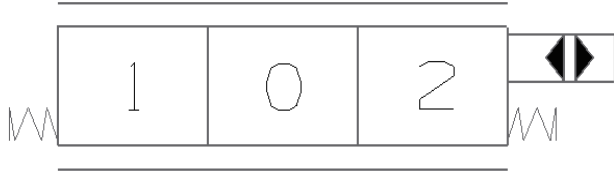
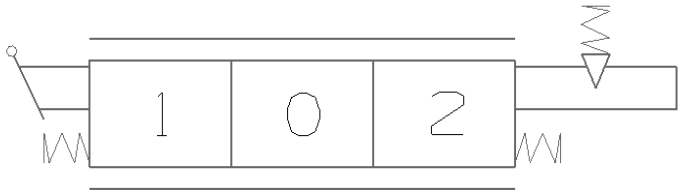
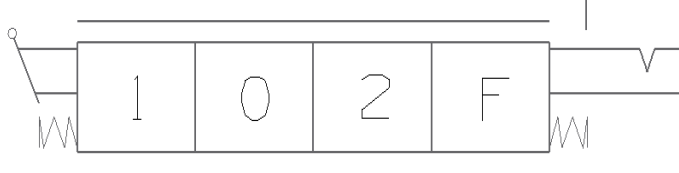
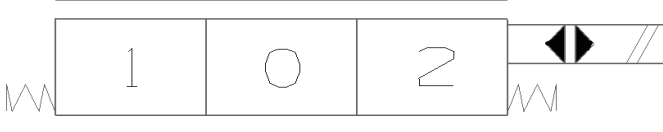
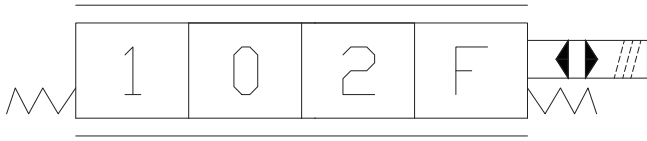
Drive Style Code	Hydraulic Schematic	Functions
KQ1		Standard manual control
KQ2		Hydraulic remote
KQ3		Manual control with mechanical detent
KQ4		Manual control with 4th position floating and detent
KQ5 (not available)		Electrical drive(on/off)
KQ6 (not available)		Electrical actuated with floating function

## Ordering Code

<b>GDV160</b>	<b>-P*</b>	<b>/***</b>	<b>-T*</b>	<b>-D*</b>	<b>-O1</b>	<b>-FG*</b>	<b>KQ*</b>
a	b	c	d	e	f	g	h

- Ⓐ Model
- Ⓑ Inlet port code
- Ⓒ Inlet relief setting(bar)
- Ⓓ Return port code
- Ⓔ Power beyond option code
- Ⓕ First spool
- Ⓖ Spool function  
FG1, FG2, FG3, FG4, FG5, FG6
- Ⓗ Drive code  
KQ1, KQ2, KQ3, KQ4, KQ5, KQ6

<b>-O2</b>	<b>-FG*</b>	<b>-KQ*</b>
i	j	k

- Ⓘ Second spool
- Ⓙ Spool function  
FG1, FG2, FG3, FG4, FG5, FG6
- Ⓚ Drive code  
KQ1, KQ2, KQ3, KQ4, KQ5, KQ6

## Ordering Example

<b>GDV160</b>	<b>-P1</b>	<b>/210</b>	<b>-T1</b>	<b>-D0</b>	<b>-O1</b>	<b>-FG1</b>	<b>KQ1</b>
a	b	c	d	e	f	g	h

- Ⓐ Model
- Ⓑ Inlet port at the front
- Ⓒ Inlet relief setting(210bar)
- Ⓓ Return port at the front
- Ⓔ Without power beyond
- Ⓕ First spool
- Ⓖ Spool function: O-type
- Ⓗ Drive mode: manual control

<b>-O2</b>	<b>-FG2</b>	<b>-KQ1</b>
i	j	k

- Ⓘ Second spool
- Ⓙ Spool function: Y-type
- Ⓚ Drive mode: manual control

## LS-TW-20F Log Splitter Valve

### Specifications

Flow	95 (L/min)
Relief Pressure	200 (bar)
Detent Release Pressure	70 to 140 (bar)
Pressure Drop (P to A or B)	3bar (at 75L/min)
Pressure Drop (P to T)	0.8bar (at 75L/min)

### Installation Dimensions and Function Symbol

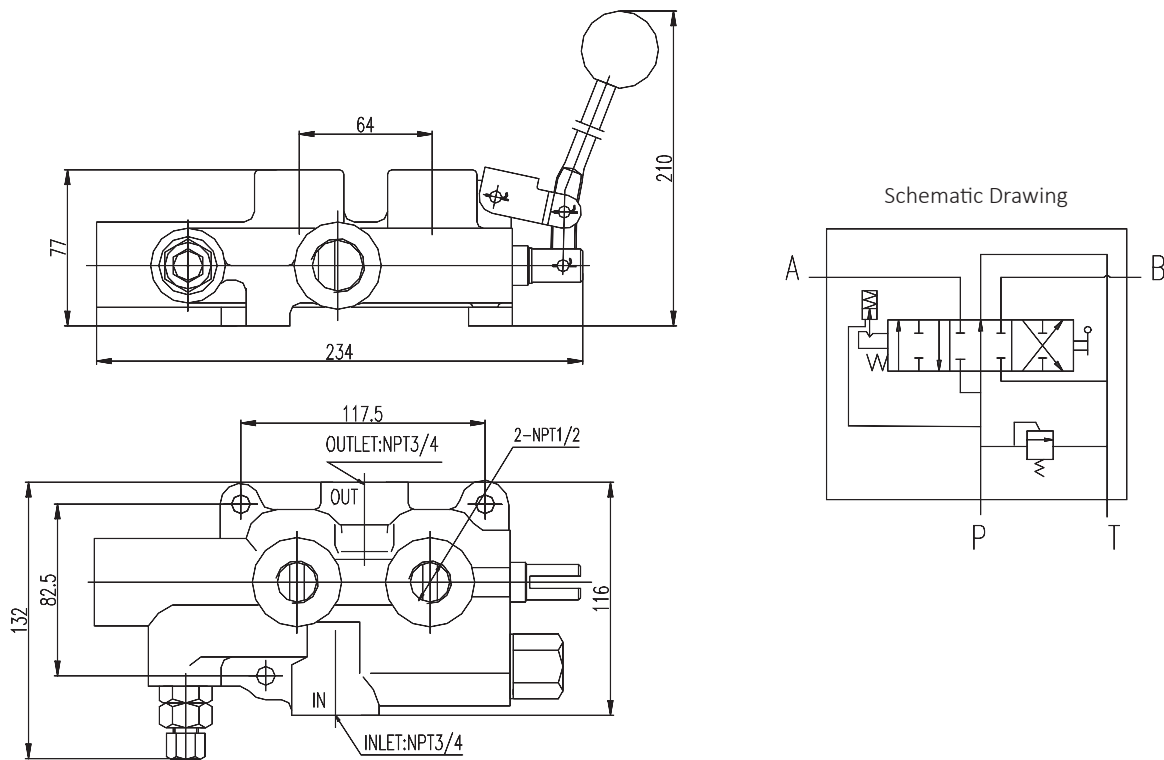

### Ordering Code

LS	-TW	20	F
a	b	c	d

Ⓐ Model

Ⓑ With pressure release detent

Ⓒ Nominal size(mm)

Ⓓ Pressure: 20Mpa

## Pressure Compensating Variable Flow Control Valve

### Specifications

Model	Oil Port	Flow(gpm)	Standard Pressure(bar)
LKF-40-3/8NPT	3/8"-NPT	0-30L/min(0-8gpm)	210
LKF-60-1/2NPT	1/2"-NPT	0-60L/min(0-16gpm)	
LKF-114-3/4NPT	3/4"-NPT	0-114L/min(0-30gpm)	

### Installation Dimensions and Function Symbol

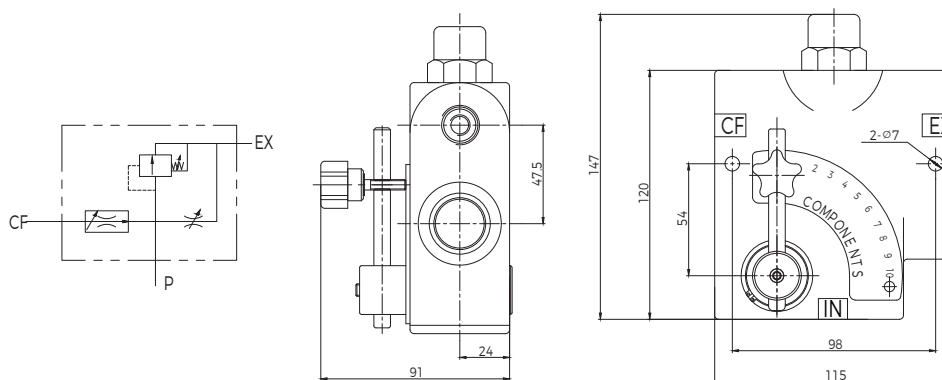

LKF model is a full range pressure compensating variable flow control. It is designed so that the orifice area varies as the lever is rotated. The outlet flow is smooth and constant regardless of the pressure on the control flow or excess flow ports. An adjustable ball spring relief allows for pressure compensated flow up to the pressure setting on the relief. Relief valves are preset at 1500 psi and adjustable range from 750 to 3000 psi.

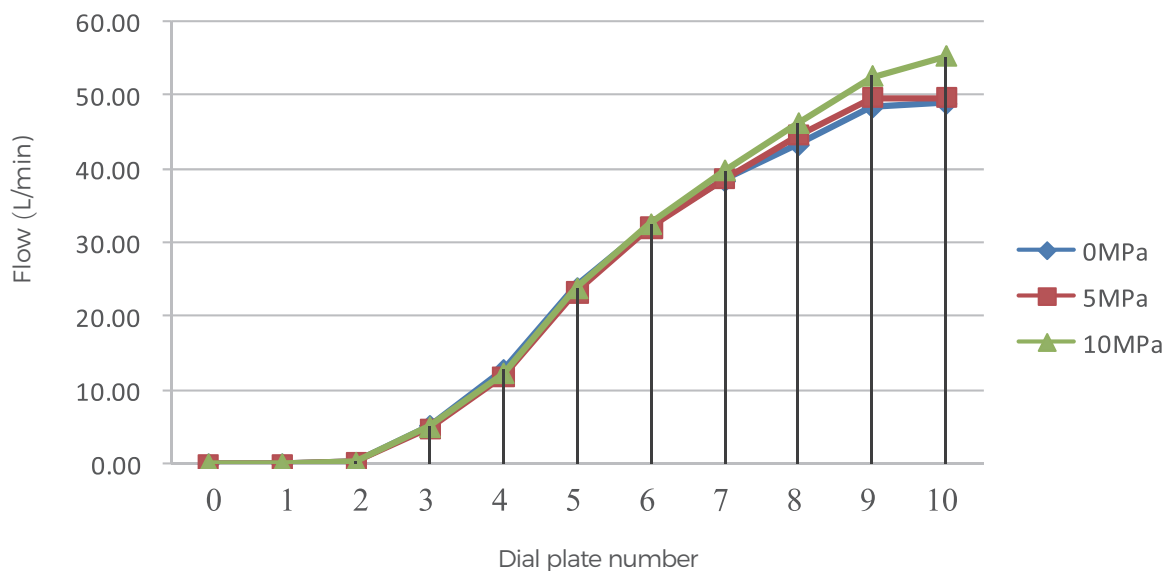



© RYAN | 2023



**Shanghai Ryan Hydraulic Fluid Power Co., Ltd**

Add. Room 2201-2202, 1717 North Sichuan Road,  
Hongkou Shanghai, China  
P.C. 200080  
Tel. +86-21-56626882  
Mail. [sales@ryanhydraulic.com](mailto:sales@ryanhydraulic.com)

